





CODEMARK™
CMA-CM40172

HEAD OFFICE

Nasahi Building Materials Australia Pty Ltd
1331 Stud Rd, Rowville, Victoria, 3181
P: 1300 2 NASAHI (1300 2 627244)
E: sales@nasahi.net.au



ABOUT NASAHI®	5
NASAHI® PANELS.....	6
ADVANTAGES OF NASAHI®	7
DESIGN PROCESS	8
DESIGN PRINCIPLES.....	9
DESIGN DETAIL CONSIDERATIONS	10
COATINGS.....	12
STRUCTURAL PERFORMANCE	13
SYSTEM OVERVIEW.....	20
EXTERNAL WALL SYSTEM INSTALLATION SEQUENCE	26
BOUNDARY WALL SYSTEM INSTALLATION SEQUENCE.....	28
WORKING WITH NASAHI® PANELS.....	32
DELIVERY & HANDLING.....	33
HEALTH AND SAFETY	34
NCC COMPLIANCE	35
MATERIAL PROPERTIES	37
PANEL REINFORCING LAYOUT	38
DETAILED DRAWINGS	40
WARRANTY & GUARANTEE	51





NASAHI

 **NASAHI**[®]
building smarter

www.nasahi.net.au

For the past 20 years Nasahi® have been one of the world's largest producers of innovative, high quality AAC materials. We have become a world leader in the production of revolutionary building materials by investing over AUD\$60 million in the most technologically advanced processes in the industry. Our production facility has the capacity of 700,000 m³ of AAC products per year, selling within China and exporting to Japan, Singapore, Malaysia, Vietnam, Philippines, UAE, Maldives, Russia, Angola, Australia, New Zealand etc. Our reputation for consistently producing high quality products is exceptional.

The Nasahi® range of building systems are regularly tested in Australia by NATA accredited laboratories. They are carefully engineered to comply with the requirements of the Building Code of Australia, and to remain at the cutting edge of product innovation.

Nasahi's in-house engineers provide project specific guidance, assisting with custom projects and bringing your ideas to life.

With warehouses located in every state of Australia, Nasahi® can easily meet demands and quickly deliver to site.

Our ISO 9001 and JIS A 5416 manufacturing processes are audited annually by independent authorities. This ensures that we meet the needs of our customers and other stakeholders while complying with statutory and regulatory requirements.

By building smarter we provide a guarantee you can trust.

NASAHI® PANELS

AUTOCLAVED AERATED CONCRETE (AAC)

Autoclaved Aerated Concrete is a lightweight precast concrete building material that provides excellent structural, thermal, fire, termite and mould-resistance. AAC is manufactured from cement, sand, lime and water; it is aerated by adding an expanding agent to the mix. The mix is poured into a large mould and allowed to rise. These large soft blocks are sliced into the required panel sizes, and are then cured in a steam pressure autoclave for up to 12 hours.

The result is a concrete panel filled with small, finely dispersed air bubbles, which is both strong and lightweight.

Embedded corrosion protected steel mesh inside the panels provide excellent strength when installed as internal walls or over a load bearing timber or steel frame. Panels are supplied in a standard width of 600mm and up to 3300mm length, and can easily be cut to size allowing fast and strong installation.

Table 1: Weight of 2200mm Long Panel

Thickness	50mm	62mm	75mm
Working Panel Weight (650kg/m ³)	43kg	54kg	65kg

Nasahi® Panels are designed to provide a superior wall cladding solution with the feel of concrete at a significantly reduced cost. Excellent airborne noise transmission properties result in a quieter, more comfortable home for your family.

Manufactured from lightweight, reinforced, autoclaved aerated concrete, Nasahi® Panels have a working density of 650kg/m³ making them highly resistant to chipping and damage during delivery and handling. Nasahi® Panels are also very thermally stable, requiring minimal expansion joints.

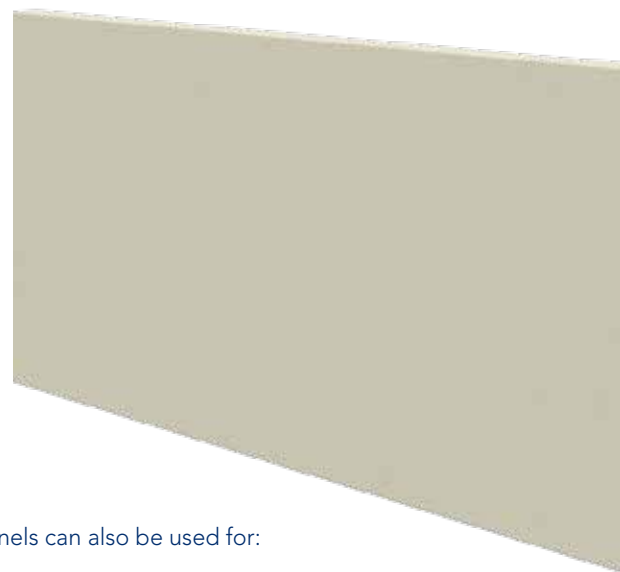

Nasahi® Panels can also be used for:

- Flooring
- Party Walls
- Fences

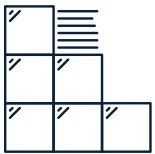

Quick Installation

3 qualified tradespeople can easily install 50m² of Nasahi® Panel per day, making it significantly faster and less labour intensive than traditional masonry.



Transportable

Panels are flat packed in packs of up to 20 improving transportability to and around site.

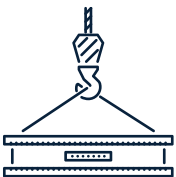

Lightweight and Strong

Nasahi® Panels weigh less than standard concrete masonry, making it convenient, lightweight, and easy to work with. Strength is provided by corrosion protected internal steel reinforcing mesh.



Fire Resistant

Nasahi® Panels are non-combustible and are compliant as external wall cladding in all Australian bushfire regions. Nasahi® Panels have been rigorously tested and will provide a FRL of 120/120/120 using standard 10mm plasterboard internal lining.

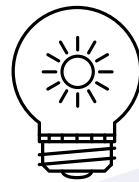

Thermal Comfort

Nasahi® Systems achieve very high thermal ratings and easily meet the NCC climate requirements of zones in Australia.



Quiet

The Nasahi® Panel's unique aerated construction provides the thermal performance of a lightweight system while delivering excellent acoustic performance like a dense masonry product.

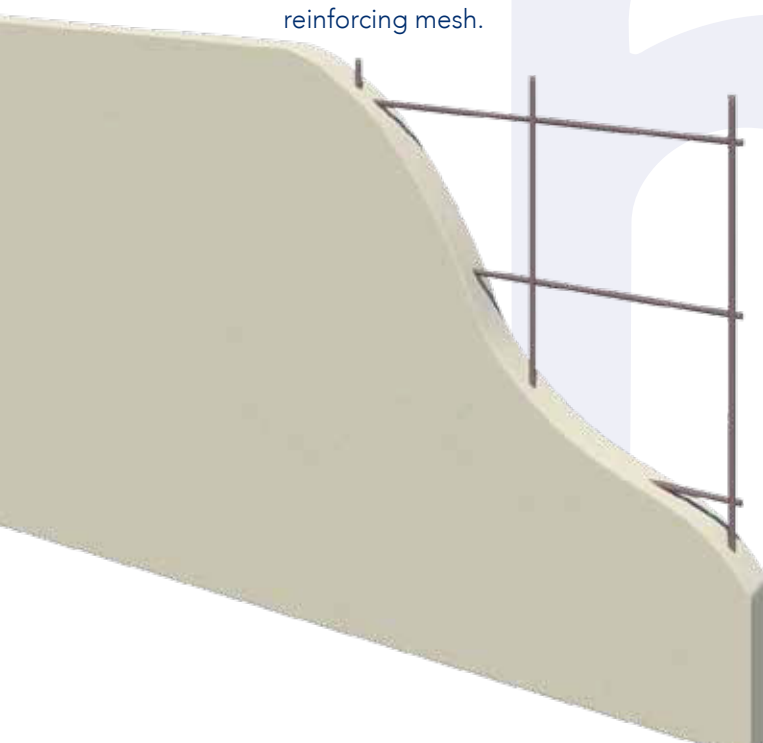

DESIGN PROCESS

This section outlines the design process that should be followed when determining the Nasahi® External Wall System design appropriate for your project.

Step 1 Site Wind Loads: Determine the site wind load requirements including wind category, terrain category, topography and other factors that are required to calculate the site wind pressures acting on the cladding.

Step 2 Other Requirements: Identify whether other NCC performance requirements apply to your project. These may include fire resistance levels, bushfire attack resistance, sound insulation performance and energy efficiency.

Step 3 Select Cavity: Using Table 5 on Page 13, or details on Page 39. Select the appropriate cavity and fixing layouts to meet the requirements outlined in step 1.

Step 4 Energy Efficiency: Using Table 7 on Page 17, select the appropriate insulation and sarking material to meet the energy efficiency and weatherproofing requirements determined in Step 2.

Step 5 Calculate Required Components: Determine the number of panels, battens and fasteners required for the project.



This technical guide specifies design principles for the Nasahi® External Wall Panel System that comply with the Performance Requirements of the NCC at the time of writing. The designer must check the adequacy of the building solution for compliance with the appropriate authority.

DESIGN PRINCIPLES

(a) Lateral wind loads experienced by the panels are transferred through the panel fasteners, and into the load bearing stud frame, which must be designed in accordance with the relevant Australian Standards for the site loads determined earlier. Battens are designed to act as non-structural cavity spacers. The frame must be designed for all bracing and hold-down requirements.

(b) Windows, doorframes and penetrations must be sealed and a water resistant approved external coating must be applied to the external surface of the panel.

(c) For boundary wall applications, panels may be installed uncoated provided that a ventilated cavity is present and studs are strung to prevent insulation from touching the inside face of the panels.

Criteria for Corner Panels

Panels within a distance of 1200mm from building corners experience higher wind loads. Due to this increase of wind load, extra battens and screws may be necessary in each direction from the corner. Batten and fixing spacing requirements are shown in details on Page 39.

Framing Design

The load bearing stud frame must be designed in accordance with NCC requirements for timber or steel frames, taking into account the permanent loads imposed by the panels as outlined in Table 4 on Page 13.

Timber Frames

Timber framing must be designed in accordance with the relevant parts of AS1684. Stud spacing and height should be designed to suit the wind loadings and panel permanent loads in accordance with local codes. Noggins must be flush fitted at a maximum of 1350mm centre spacing.

Steel Frames

Steel framing must comply with NASH Standard 2005. For steel framing the minimum framing specification is 'C' section studs and noggins of overall section size 75mm web and 32mm flange. Minimum Steel thickness must be in accordance with AS3623 and AS/NZ4600.

Bracing

Timber and steel framed walls must be braced for a medium weight wall cladding in accordance with AS1684 for timber framing and AS3623 and AS/NZS4600 for steel framing.



Wall Panel Layout

Construction should be designed in 275mm horizontal modules.

This will help minimise the number of panels required during construction, and reduce the likelihood of cutting through the embedded corrosion protected steel mesh. Steel reinforcing mesh layout can be seen in Details on Page 38.

Control Joints

Render cracking is caused by stresses due to various building materials expanding and contracting at different rates. Control joints shall be a minimum of 5-10mm wide by 5mm deep and consist of a backing rod and flexible sealant (fire rated where required). See Details 10.1 and 10.2 on Page 47.

Vertical	Horizontal
<ul style="list-style-type: none"> • At all internal corners • At centres not exceeding 6m • At the position where wall height changes • At a change in thickness of a wall • At the junctions of walls constructed of different materials • At control joints or construction joints in supported concrete slabs • On both sides of openings greater than 2.5m wide • As per engineers design specification 	<ul style="list-style-type: none"> • When wall height exceeds 8 metres; and • When timber joists are not seasoned* a minimum gap of 20mm is required if the panel joints are within the FLOOR JOIST ZONE (See Detail 6.2 on Page 46.) • Horizontal control joints are not required where engineered* joists are used, and panel joins are not within the FLOOR JOIST ZONE. <p><i>*Less than 1% shrinkage of the floor joist depth as confirmed by the design engineer</i></p>

Penetrations

Services should be run through the frame, not installed in the wall cavity. Where services penetrate through the wall, a 5-10mm gap should be created around the service. Gaps must be filled with backing rod and an appropriate flexible sealant (fire rated where specified). A fire rated penetration collar may be required around the service and penetration, check with the project engineer.

Footings

Panels can either be supported on an AS2870 compliant rebated slab edge, or hung from the load-bearing frame overhanging the concrete slab or timber base. Maximum overhang 250mm as shown in Detail 1.1 on Page 40. For bushfire rated applications, rebated slab installations are recommended and appropriate measures must be taken for control of burning embers as required by the NCC.

Termites

Nasahi® Panels are resistant to termites; however, termite protection is a mandatory requirement to protect internal building components. Termite protection must be installed in accordance with local codes and NCC requirements taking into account state variations.

Consider the difference that Nasahi® can bring to you.

COATINGS

Nasahi® approves all coatings achieving the performance levels outlined below as suitable for use with their External Wall System. It is the responsibility of the installer to ensure these specifications are met, complete an Installation Compliance Certificate and submit copies to both the builder and Nasahi®.

Table 2: Coating Performance Level

Test	Performance Requirement	Units
Water Transmission Resistance	<10	g/m ² /24hr/1kPa
Water Vapour Permeability	w. sd ≤ 0.2	kg/(m ² .h ^{0.5})
Co-efficient of Water Absorption	w ≤ 0.5	kg/(m ² .h ^{0.5})
Equivalent Air Layer Thickness of Water Vapour Diffusion	Sd ≤ 2	m
Durability	Minimum 7-year warranty	
Elasticity	Bridge a minimum crack width of 1mm	

Note: Minimum coating thickness specified by supplier may vary provided the above specifications are met. A co-efficient of water absorption ($w \leq 0.5$) means that minimal water is absorbed regardless of time period. A Coating with $Sd \leq 2m$ has less resistance to water vapour diffusion (escape) than a static 2m thick layer of air.

Surface Preparation

Before applying the coating system, the applicator must ensure that all required penetrations and fire collars have been correctly installed and Nasahi® Panels are dry and clean of debris/oil. Surface protrusions must be trimmed back and large imperfections filled with Nasahi® Panel Adhesive. Exposed reinforcing bars must be coated with Nasahi® Corrosion Protection Touch Up Paint.

RECOMMENDED COATING SYSTEM

Nasahi® recommends the following system be used on External Walls as it has been shown to meet the approved coating specification.

Table 3: Recommended Coating System

External Corner Angles	32mm x 32mm Aluminium, PVC or Stainless Steel corner angles.
Primer Coat (to manufacturer specifications)	Primer/Sealer to enhance adhesion (if required by coating manufacturer)
Base Coat Render	High build acrylic, Portland cement-based render with minimum thickness of 3mm. This base coat must encapsulate the reinforcing mesh.
Reinforcing Mesh	165g/m ² Alkali resistant fibreglass mesh with minimum aperture 5mm square embedded into the base coat render.
Texture Coat	Cement based polymer modified dry powder or wet pre-mixed full acrylic texture coating with minimum thickness 1mm applied with trowel or float over base coat.
Paint System	A minimum of two coats of 100% acrylic-based exterior paint should be applied to a thickness of 150um per coat, and have crack bridging capability of 5 times the total dry film thickness.

Note: Where coatings deviate from the recommended coating system outlined above, the coating must meet the approved coating specification and be warranted by the manufacturer.

The Nasahi® External Wall System is a non load-bearing system that is designed to be installed onto a load bearing timber or steel frame.

Panel Weight

For panel on slab installations, the panel weight is supported by the slab and no additional frame design is required. In the event that the panels are suspended from the frame (e.g. ventilated cavity), the frame designer must allow for the weight of the panel and external coatings as shown below:

Table 4: Panel Loads

Panel Thickness	50mm	62mm	75mm
Design Dead Load (kN/m ²)	0.36	0.45	0.53
Panel Weight (kg/m ²)	33.2	41.6	50.1

Wind Zone

The Nasahi® External Wall System complies with the NCC requirements for wind zones up to and including N6, C4 (as specified in AS4055).

Ensure batten and fastener spacing are in accordance with the wind zone requirements in Details on Page 39.

Table 5: Batten and fastener spacing requirements for NCC compliance

Wind Zone	Max Horizontal Batten Spacing (mm)		Number of Fasteners Per Panel In Each Batten	
	Corner Zone	Typical Zone	Within 1200mm of corners	Away from Corners
N1, N2, N3, C1	600	900	2	2
N4, C2	600	600	3	2
N5, C3	600	600	3	3
N6, C4	450	450	3	3



IMPACT RESISTANCE

The Nasahi® External Wall System has been designed to provide excellent soft and hard body impact resistance and meet all related NCC requirements.



DURABILITY

The Nasahi® External Wall System when subjected to typical conditions will provide many years of maintenance free service, and has been designed to meet the durability requirements of the NCC.

FIRE RESISTANCE

Nasahi® Panels are inherently non-combustible, but in the event of fire Nasahi® Panels do not emit any toxic gases or vapours.

The Nasahi® External Wall System meets the performance requirements of the NCC, providing a Fire Resistance Level (FRL) of up to **120/120/120** using standard 10mm plasterboard internal lining.

* Note: Refer to fire Certificate No: SFC 38259000.4 for System FRL

BUSH FIRE ZONE COMPLIANCE

The Nasahi® External Wall System has been designed to comply with all six Bush Fire Attack Level categories (BAL) in the NCC.

Bush Fire Zones are defined as:

BAL	Description	Requirement for External Walls	Nasahi®
Low	Minor attack from radiant heat and flame. Some attack by burning debris possible.	No special construction requirements.	✓
12.5	Significant attack by burning debris. Radiant heat not greater than 12.5kW/m ² .	Non-combustible wall material required up to 400mm above ground or decks. Ember ingress protection required.	✓
19	Significant attack by burning debris. Radiant heat not greater than 19kW/m ² .	Non-combustible wall material required up to 400mm above ground or decks. Ember ingress and radiant heat protection required.	✓
29	Significant attack by burning debris. Radiant heat not greater than 29kW/m ² . Some flame contact is possible.	Non-combustible wall material required. Ember ingress and radiant heat protection required.	✓
40	Radiant heat levels and flame contact is likely to significantly threaten building integrity.	Non-combustible wall material required or tested for bushfire resistance to AS1530.8.1.	✓
FZ (Flame Zone)	Significant radiant heat and high likelihood of flame contact from the fire front threatening building integrity.	Non-combustible material with a minimum thickness of 90mm; or FRL of -/30/30 when tested from outside; or tested for bushfire resistance to AS1530.8.2	✓

Note: In bushfire applications, panels should not be installed in a manner that allows debris to accumulate underneath the panel. Burning ember ingress into the cavity must be prevented in accordance with NCC and AS3959 requirements.

The Nasahi® External Wall System has been designed to comply with all Fire Resistance requirements of the NCC.

ENERGY EFFICIENCY

The Nasahi® External Wall System has been designed to achieve energy efficiency levels that comply with the climate zone requirements outlined in the NCC.

This exceptional level of performance is due to the aeration within the Nasahi® Panels providing very high levels of thermal resistance.

Table 6: NCC 2016 Climate Zone Requirements

Climate Zones	1, 2, 3,	4, 5, 6	7	8
Minimum Total R-Value for External Walls	Typical wall – R3.3 South facing wall – R2.8 Shaded with a projection angle of: 15 degrees but not more than 45 degrees – R2.8 More than 45 degrees – R2.3 Outer surface solar absorptance value less than 0.6 – R2.8	Typical wall – R2.8 South facing wall – R2.3 Shaded with a projection angle of: 30 degrees but not more than 60 degrees – R2.3 More than 60 degrees – R1.8	Typical wall – R2.8	Typical wall – R3.8

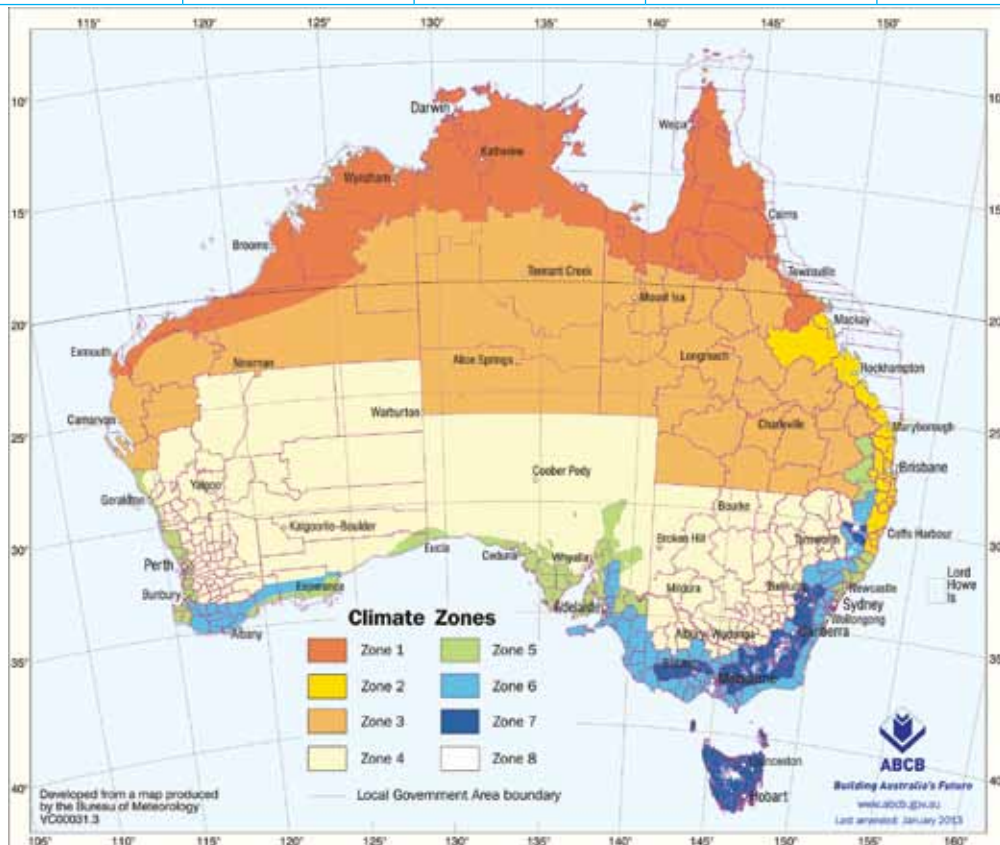

Image sourced from the Australian Building Codes Board (ABCB) www.abcb.gov.au



An exceptional level of performance

Table 7: System R-Values

Insulation	50mm			62mm			75mm		
	R2.5	R2.0	None	R2.5	R2.0	None	R2.5	R2.0	None
Render Coating									
Nasahi® Panel									
Reflective Sarking	3.4 W	2.9 W	1.5 W	3.5 W	3.0 W	1.6 W	3.6 W	3.1 W	1.7 W
Cavity (16-35mm)	3.2 S	2.7 S	1.4 S	3.3 S	2.8 S	1.5 S	3.4 S	2.9 S	1.5 S
10mm Plasterboard									

Notes: W = winter; S = summer; 90mm Frames must be used with R2.5 Insulation to prevent excessive compression.

Sarking Wall Wrap

It is highly recommended that Sarking be used with the Nasahi® External Wall System to ensure a cavity is maintained between the Nasahi® Panel and insulation, which further improves the energy efficiency of the system.

Condensation

For climates where condensation control is a concern, a ventilated cavity and sarking is recommended to allow airflow within the wall cavity space, and removal of any water vapour. Penetrations through the wall should be sealed, and sarking should be installed to separate the ventilated cavity from the internal space and minimise heat loss.





ACOUSTIC PERFORMANCE

The Nasahi® External Wall System has been designed to provide excellent acoustic performance.

Sound insulation materials can be incorporated into the system to significantly increase the acoustic performance against outside noise.

The full range of Nasahi® External Wall System Acoustic Performances can be found on our Website.

A 10db increase in acoustic performance is approximately equivalent to a halving of loudness.

Table 8: Typical Acoustic Performances of External Walls

Description	System Thickness (mm)	Acoustic Performance Rw+Ctr
Nasahi® 50mm External Wall System with Timber Frame	170	43
Brick veneer, Timber Frame and Internal Plasterboard	250	50
Rendered EPS, Timber Frame and Internal Plasterboard	174	29
Weatherboards and 120mm mineral wool insulation	120	23

Note: Exact acoustic performance of the external wall system is dependant on the specification of the products used. Figures obtained from Renzo Tonin & Associates report: TJ101-01F02.

WEATHERPROOFING

The Nasahi® External Wall System meets the performance requirements of the NCC. In the event that water enters the wall cavity, the system is designed to allow excess moisture present to be dissipated without causing permanent damage to the building elements.

The system is designed with four layers of defense to prevent moisture entry into the habitable space:

- External Coating
- Nasahi® Panel
- Internal Cavity
- Breathable Sarking



Penetrations must be sealed and flashed in accordance with the Nasahi® construction details provided, and the NCC. It is the responsibility of the project engineer to verify that all non-standard installation details will meet the performance requirements of the NCC.

In the event that a wall is built on a boundary (with no penetrations) and is abutting the wall of an adjoining property and cannot be coated, the uncoated Nasahi® External Wall System must be installed as a drained/ventilated cavity system in order to comply with requirements of the NCC or capped from the adjoining property as shown in Details 12 and 13 on Pages 48 to 50.

ENVIRONMENTAL

Nasahi® delivers a diverse number of environmental benefits over particle board and concrete. As environmental consciousness and social responsibility increases, Nasahi® is striving to set new sustainability standards in building materials and residential living.



Panel fasteners must penetrate through the cavity battens, and into the wall frame by a minimum of 30mm for timber frames and a minimum of 15mm for metal frames.

Timber Frames

Bugle Batten Head SDS
Type 17, Class 3 Screws



Steel Frames

Hex Head Self-Drilling
Class 3 Screws



NOTE: A minimum of Class 3 fasteners must be used with the Nasahi® External Wall System. AS3566 corrosion class 3 fasteners must be used in NCC defined corrosion zones 1, 2, 3, and 4. Class 4 or Grade 304 stainless steel must be used in the sea spray zone.

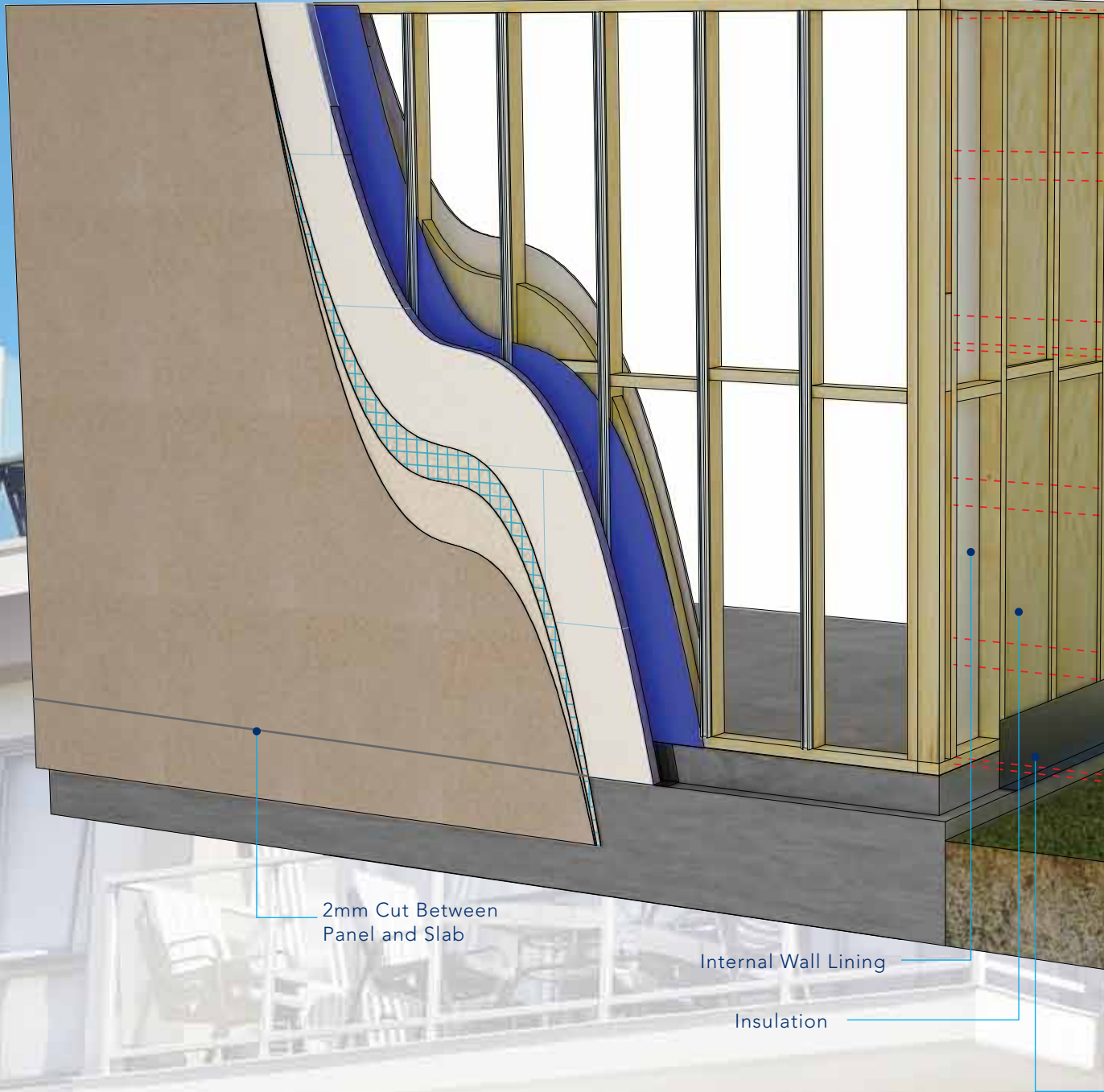

Nasahi Panels

Nasahi® Panels are manufactured from Autoclaved Aerated Concrete (AAC), embedded with coated steel reinforcing mesh, in a standard width of 600mm and up to 3300mm length.

Thickness	50mm	62mm	75mm
Dry Panel Weight (495kg/m ³)	36kg	46kg	55kg
Working Panel Weight (650kg/m ³)	43kg	54kg	65kg

DPC

Damp-Proof Courses must comply with AS2904, and be installed in accordance with NCC requirements.

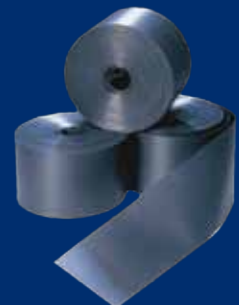

Batten Fasteners

Timber Frames

12-11 x 25mm

Hex Head Type 17 Screws



Steel Frames

10-16 x 16mm

Hex Head SDS Screws

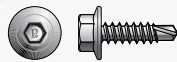

Cavity batten fasteners are used to temporarily support the battens in place during system installation.

Metal Battens

G300 Galvanised steel cavity battens have BMT of 0.42mm and are supplied up to 40mm wide and with heights of:

- 16mm
- 24mm
- 35mm

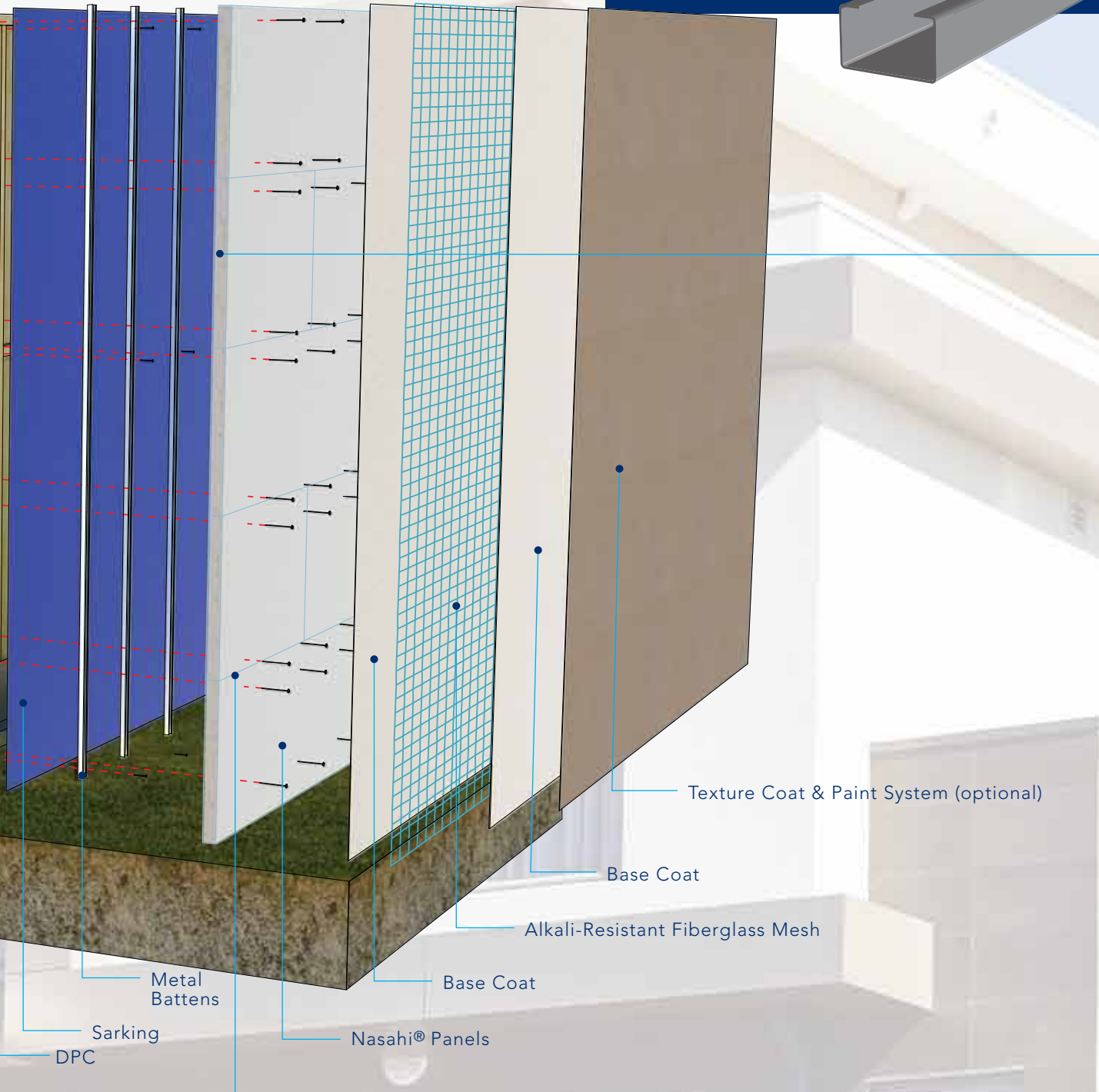
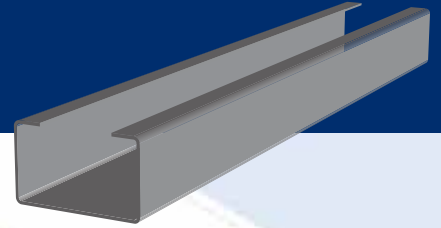

Adhesive

Nasahi® Adhesive comes in 20kg bags and it is used to glue and seal panel joints, and to fill screw heads



Touch-up Paint

If Nasahi® Panels are cut to size, all exposed reinforcing steel must be treated with Nasahi® Corrosion Protection Touch Up Paint in accordance with the instructions on the container.



1. Eave Details - Page 44

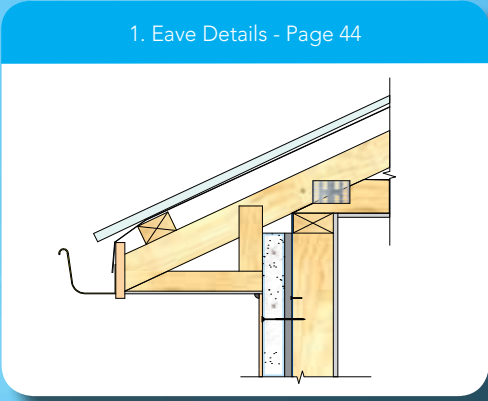

2. Window Head - Page 43

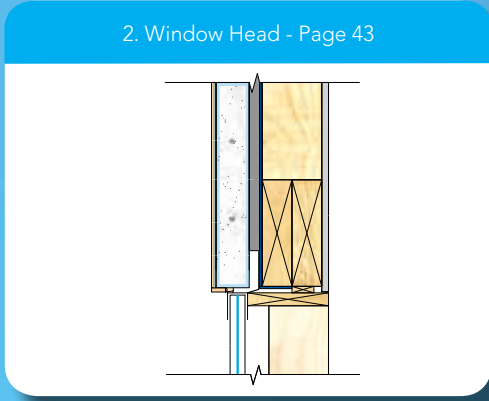

3. Base Details - Page 40

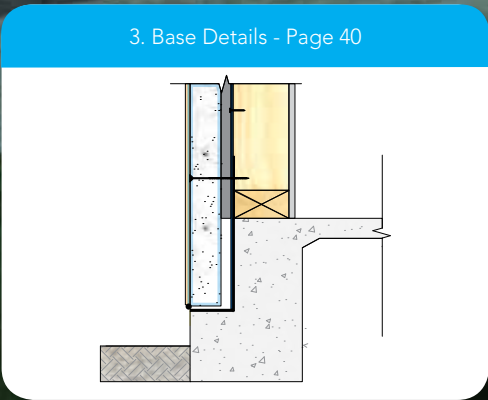

4. External Corner - Page 42

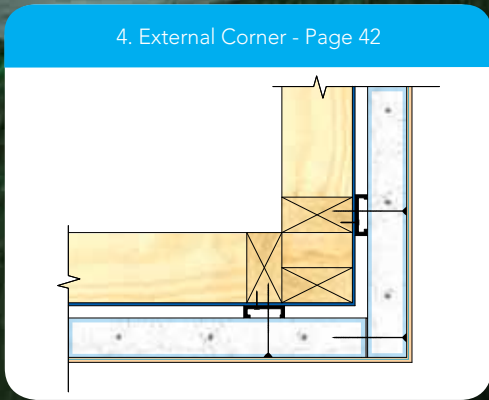

5. Internal Corner - Page 42

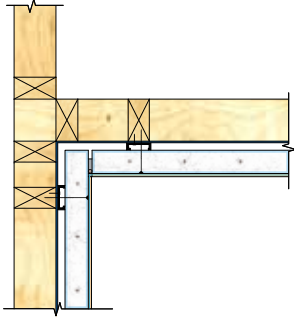

6. Flush Eave - Page 44

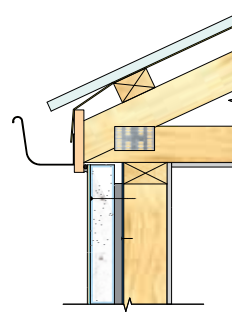

7. Window Sill - Page 43

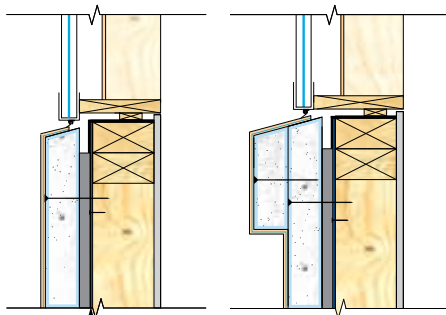

8. Parapet Detail - Page 47

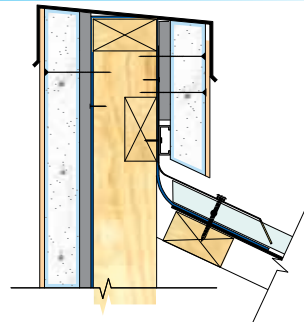

1. Control Joint - Page 47

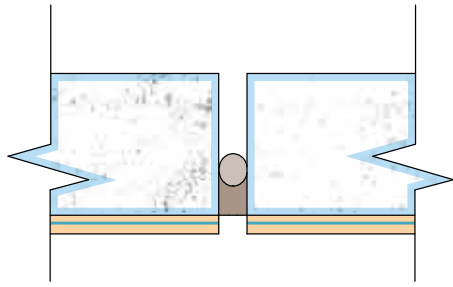

2. Meter Box - Page 46

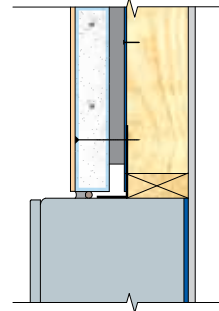

3. Internal Floor Junction - Page 46

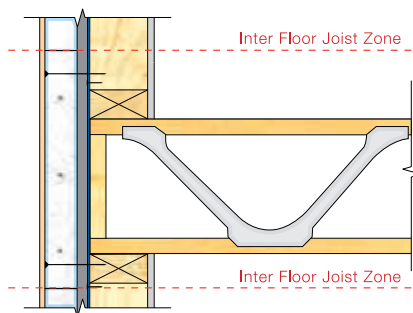

4. Gutter Fixing - Page 47

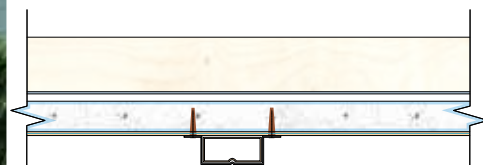

5. Lower Roof Detail - Page 45

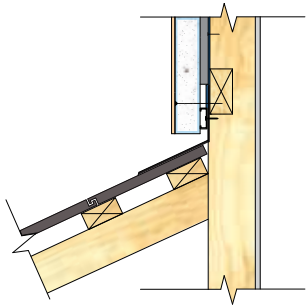

6. Eave Detail - Page 44

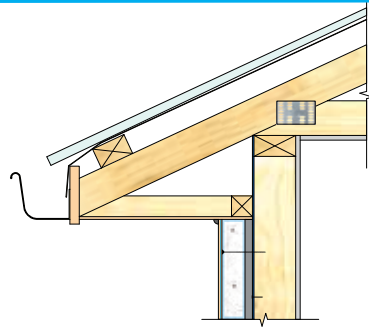

7. Cladding to Brick Detail - Page 45

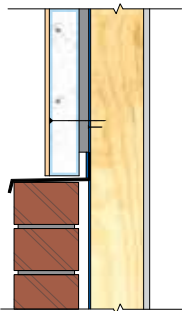

8. Column Detail - Page 46

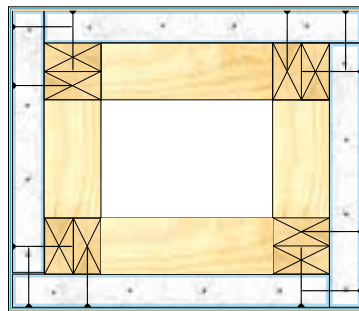

EXTERNAL WALL SYSTEM INSTALLATION SEQUENCE

Stage 1: Preparation

1. The wall frame and roof must be completed prior to installation of the Nasahi® External Wall System. A pre-cladding check list is available on our website.
2. DPC must be installed on slab and up-stand in accordance with NCC requirements.
3. Use a straightedge to ensure framing is straight. Pay particular attention to corner studs that they are straight and plumb.
4. Where specified, install wall wrap in accordance with the manufacturer's instructions.

Stage 2: Batten Installation

5. Attach battens vertically to each stud. Batten spacing must comply with the structural requirements for the Wind Zone of the project; refer to Table 5 on Page 13 or Details on Page 39.
6. Flashings must be installed around penetrations in accordance with NCC requirements.

Stage 3: Nasahi® Panel Installation

7. Starting at a corner, rest the Nasahi® Panel on the slab rebate, push the panel horizontally hard up against the battens;
8. Use a spirit level to ensure that the Nasahi® Panel is level and is either flush or overhanging the slab edge rebate.
9. Screw fix through the exterior face of the Nasahi® Panel, through the batten and into the frame. Fixing spacing must comply with Table 5 on Page 13 or Details on Page 39. Screws must be a minimum of 50mm in from the panel edge.

10. The screw head must penetrate 5-10mm into the panel face.

11. Nasahi® Panels can be cantilevered a max of 500 mm beyond the stud. If panels are misaligned use back blocking as required.

Stage 4: Panel Adhesive

12. Apply approximately 2-3mm thick Panel Adhesive to vertical edge of the panel. Install the next panel hard against it, ensuring it is level and join is fully sealed.

13. Screw fix panel as per Step 9 above.

14. Repeat around the perimeter of the building.

15. Apply approximately 2-3mm thick Panel Adhesive to the horizontal top edge of the panel.

16. In a stretcher-bond pattern lay the next row of panels with a minimum of 275mm overlap of the Nasahi® Panel below, then screw fix as outlined above ensuring it is level and joints are fully sealed.

17. If panels are cut to length, ALL exposed steel reinforcement must be treated with Nasahi® Anti-Corrosion Touch Up Paint.

18. Penetrations & Services must be sealed in accordance with the Plumbing and Electrical Service Section on Page 32.

19. Upon project completion, the installer and renderer must both complete a Nasahi® Installation Compliance Certificate and submit to both the builder and Nasahi®.



<p>1. Install DPC and Wall Wrap (Recommended)</p> <ul style="list-style-type: none"> • Wall wrap overlaps should be taped. 		
<p>2. Install Nasahi® Cavity Battens and vermin control strip (required in suspended applications)</p> <ul style="list-style-type: none"> • Determine required batten spacing for wind zone and layout using Table 5 on Page 13 or Details on Page 39. 		
<p>3. Install Nasahi® Panel</p> <ul style="list-style-type: none"> • Start at one corner, finish bottom row first making sure panels are level. • Fixings as per Table 5 on Page 13 or Details on Page 39. 		
<p>4. Apply panel adhesive to vertical and horizontal joints.</p> <ul style="list-style-type: none"> • Install next row in Stretcher-Bond pattern. Minimum panel stagger 275mm. • Treat all exposed reinforcement mesh with Nasahi® Anti-Corrosion Touch Up Paint. 		
<p>5. Apply a Nasahi® Approved Coating System. (Refer to Specification on Page 12)</p>		

BOUNDARY WALL SYSTEM INSTALLATION SEQUENCE

STAND UP FRAME METHOD (NAsahi® PANELS FIXED TO EXISTING BUILDING)

This method may only be used when builder is constructing adjoining properties consecutively or permission to fix to existing wall is granted by adjoining neighbour.

1. Fix temporary batten (minimum 20mm thick) to the external face of Wall 1.
2. Begin Wall 2 construction by temporarily fixing the Nasahi® Panels through the temporary batten and into the existing wall. These fixings must be removed and screw holes patched once Frame 2 is installed. When using EPS battens as a temporary batten, the temporary batten may remain in the cavity but fixings must be removed and screw holes patched.
3. Prop the Nasahi® Panels as required until Frame 2 is installed.
4. Construct Wall 2 frame flat on the ground.
5. Prepare Frame 2 for fixing to Nasahi® Panel:
 - a. If using Top Hat Method, see Detail 12.2 on Page 48, fix the top-hat section by screwing one leg of the top hat to the stud, and the other leg of the top hat to the top plate, noggin and bottom plate at maximum 600mm centres. Stand up Frame 2 against Wall 2, fix top hats to Wall 2 using 12G x 45mm Hex Head screws with 2 fasteners per panel in each top hat.
 - b. If using Batten Clip Method, see Detail 12.3 on Page 48, fix metal batten on Wall 2 at max 600mm centres using 12G x 45mm Hex Head screws. Stand up Frame 2 against metal battens, attach batten clip to battens and fix using two 12-11 x 25mm Hex Head Type 17 Screws into top plate, noggin and bottom plate.
6. Ensure temporary fixings holding Wall 2 to existing wall, and temporary battens are removed once Frame 2 is installed.
7. Patch all screw holes in Wall 2.
8. If slab edge does not have a minimum 50mm rebate for Nasahi® Panels to rest on, capping over the completed wall cavity is mandatory as per Details 13.1 to 13.4 on Pages 49 and 50.

BOUNDARY WALL OPTION A (STAND UP FRAME)

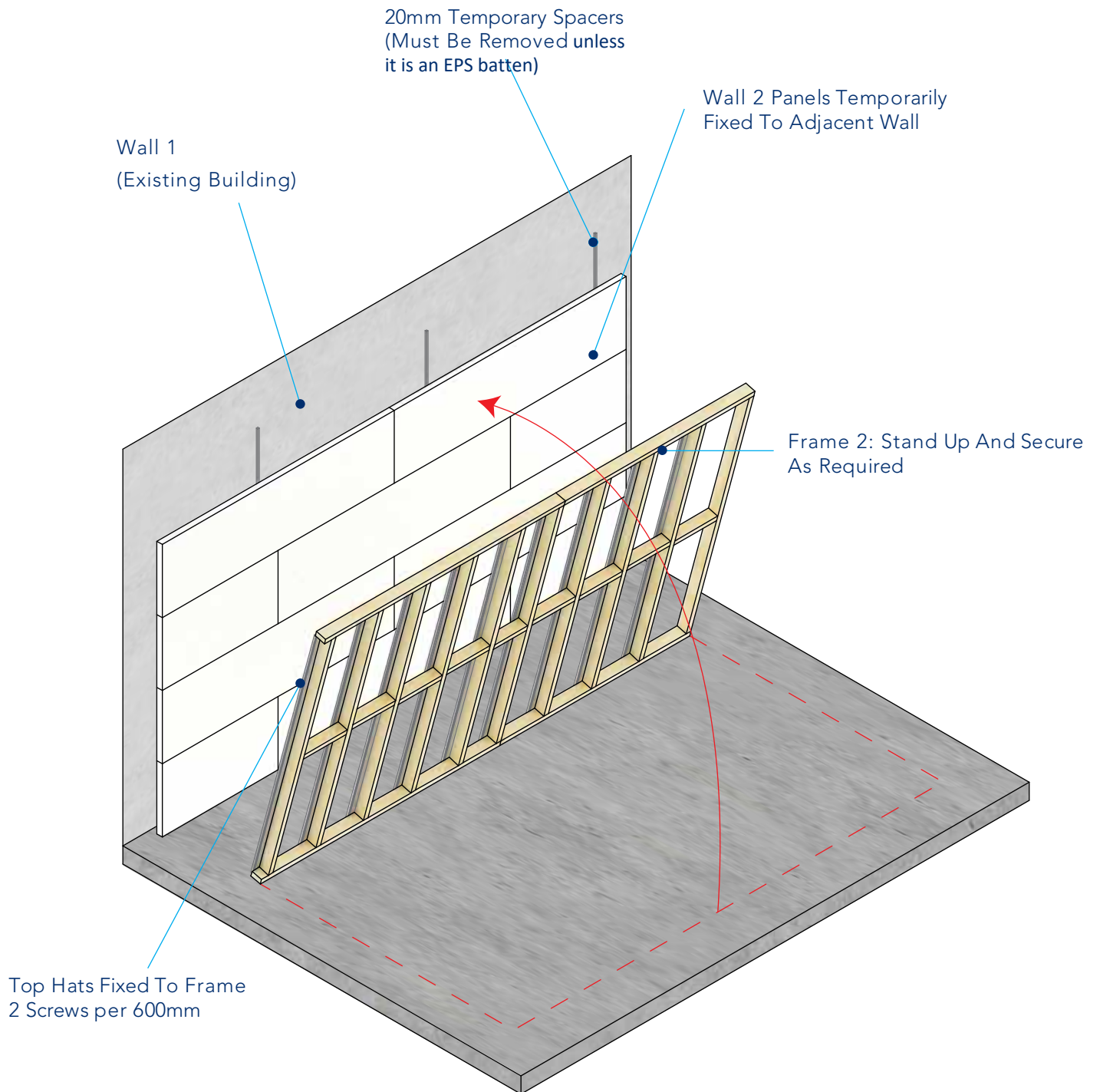



BOUNDARY WALL SYSTEM INSTALLATION SEQUENCE

SLIDING PANEL METHOD (NAsahi® PANELS NOT FIXED TO EXISTING BUILDING)

1. Construct Frame 2 for fixing to Nasahi® Panel:

a. If using Top Hat Method, see Detail 12.2 on Page 48, construct the frame flat on the ground and fix the top-hat section by screwing one leg of the top hat to the stud, and the other leg of the top hat to the top plate, noggin and bottom plate at maximum 600mm centres.

b. If using Batten Clip Method, see Detail 12.3 on Page 48, the frame is constructed then metal battens and clips are installed at Max. 600mm centres. Ensure there is at least 50mm clearance between external panel face and existing building (min 115mm from Frame 2 to face of Wall 1).

2. Slide Nasahi® Panels into the wall cavity from one end and fix to either top hats or batten clips using 12G x 45mm Hex Head Screws.

3. Panels on a boundary wall may be installed in a stacked bond configuration.

4. If slab edge does not have a minimum 50mm rebate for Nasahi® Panels to rest on, capping over the wall cavity is mandatory as per Detail 13.1 to 13.4 on Pages 49 and 50.



BOUNDARY WALL OPTION B (FRAME IN POSITION SLIDE IN PANELS)

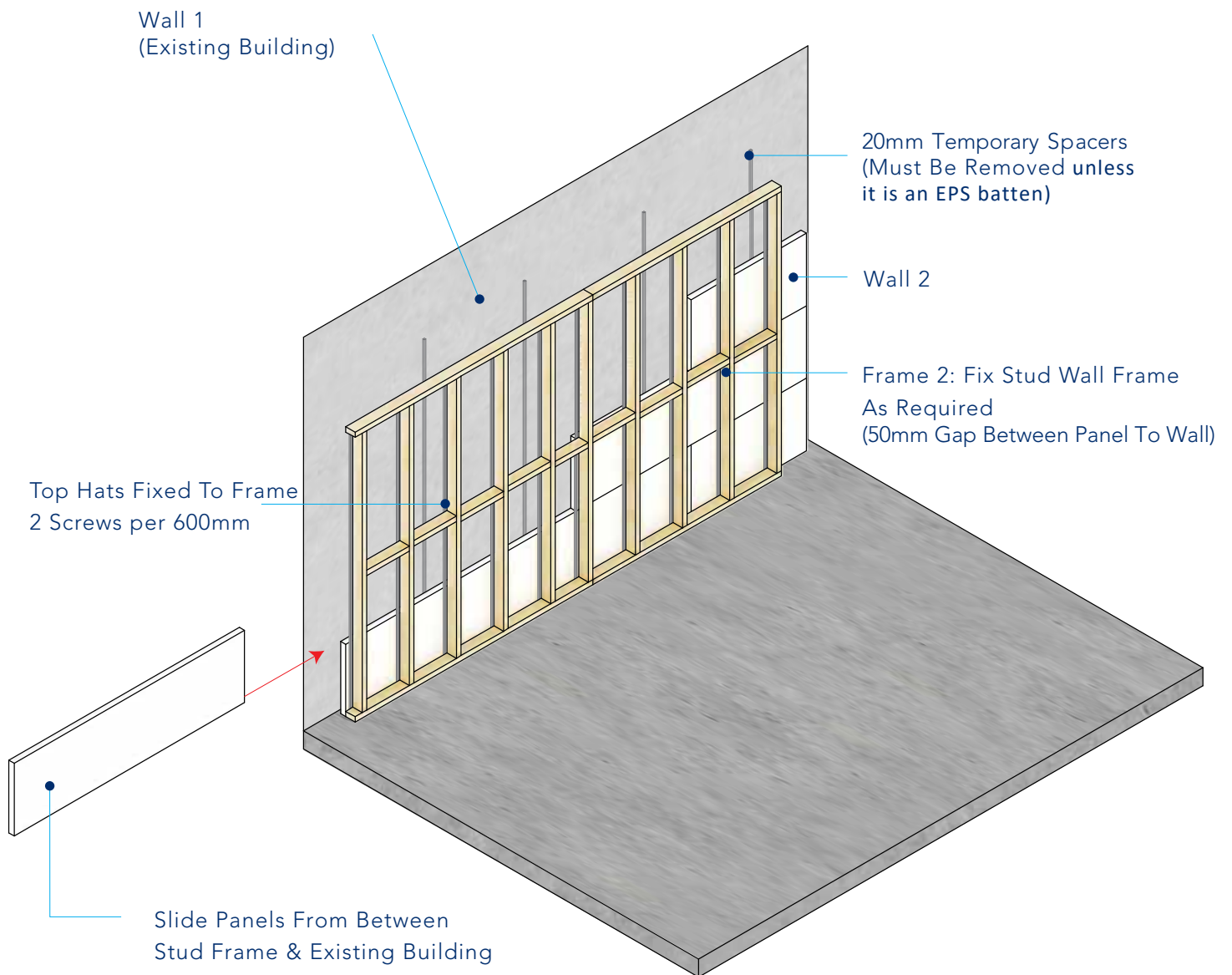

WORKING WITH NASAHI® PANELS

CUTTING PANELS

Nasahi® Panels can easily be cut to the required length, using power or hand tools.

Nasahi® Panels are delivered to site flat packed. The flat packs can be used as a cutting bench for other panels as required. Any reinforcement exposed during cutting must be coated with Nasahi® Corrosion Protection Touch Up Paint.



BASIC TOOLS REQUIRED TO INSTALL NASAHI® PANELS

- Saw (with Diamond Blade)
- Drill (for drilling penetration holes and screwing fasteners)
- Vacuum
- Mixing Buckets
- Hawk and Steel Trowel
- Rasp (Sanding Float)

DELIVERY

Nasahi® Panels are delivered to site in flat packs of up to 20.

Each pack has a wet mass of approximately 900kg, including packaging.

Panel packs must only be stacked one pack high and must be properly supported on level ground.

If packs are to be placed on any type of structure, always consult the project engineer to verify the structural adequacy of the structure.

Nasahi® Panels should be stored on a level surface and never more than one pack high.

MANUAL HANDLING

To reduce the likelihood of damage, handling of Nasahi® Panels around site should be kept to a minimum. When lifting a panel, turn onto its long edge and support the weight by lifting with two people as shown below. Before lifting panels a manual handling risk assessment must be performed to ensure personal injury risk is minimised.

Packs should be unloaded as close as possible to the installation area; however, where this is not possible Nasahi® recommends the use of trolleys and/or other mechanical devices.

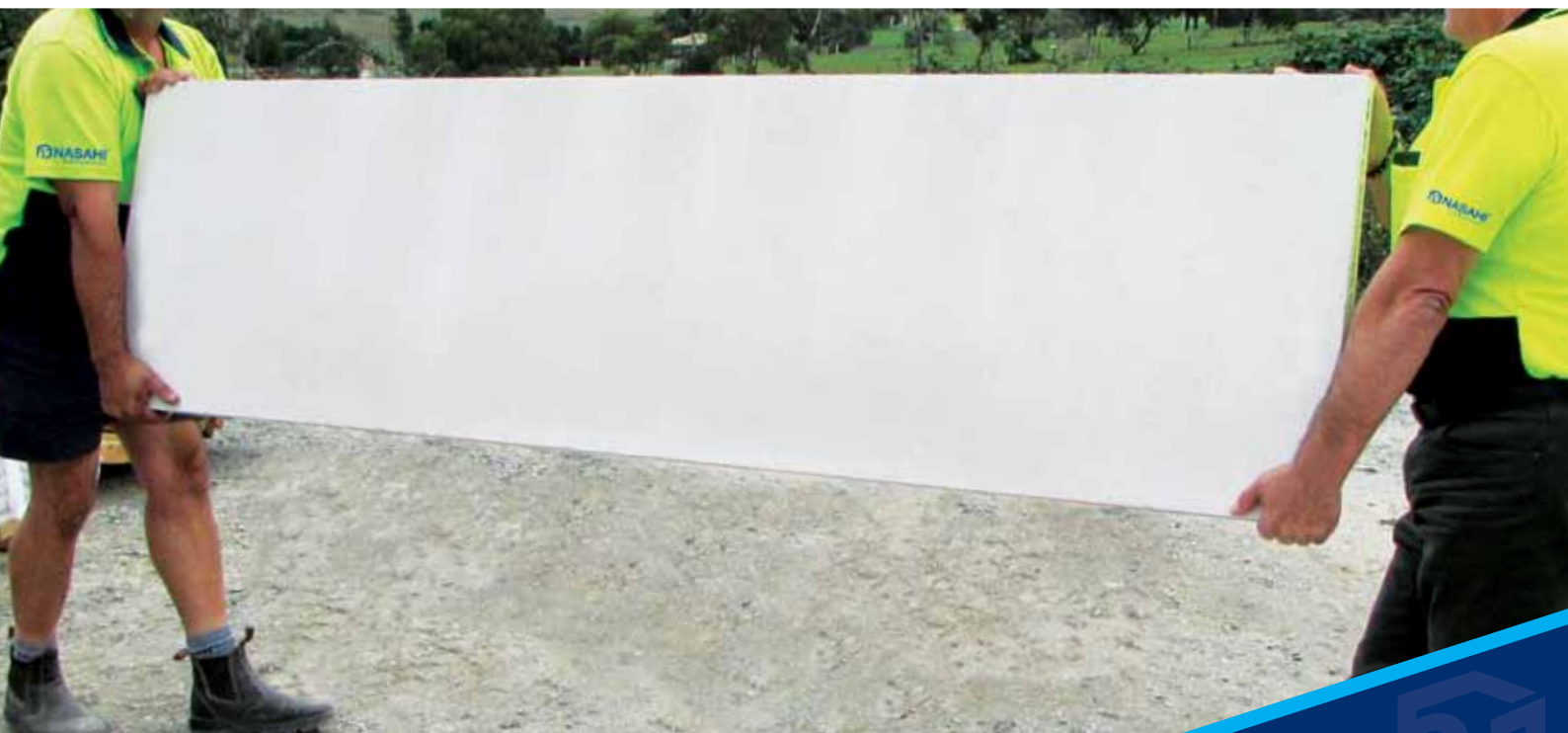

HEALTH AND SAFETY

All quarry products, including bricks, concrete and Nasahi® Panels contain Crystalline Silica, or Silica Dust.

SAFETY

Prolonged exposure to Silica Dust without the correct PPE can be harmful and potentially cause skin irritation and life threatening health hazards such as bronchitis, silicosis and lung cancer.

Silica dust is generated when cutting, drilling or moving the panels.

The site should be cleaned of dust regularly and when using power tools these should be fitted with an efficient, well-maintained dust extraction system.

Nasahi® Panels do not contain any additives that are known to cause health problems; however, because of the risk of exposure to Silica Dust it is recommended that the correct PPE is worn.

The Nasahi® External Wall System Installer is responsible for informing all employees of these Health and Safety requirements under the Occupational Health and Safety Act.

Personal Protective Equipment (PPE)

When working with Nasahi® Panels, it is recommended that the following Australian compliant PPE is worn as a minimum:

- P1 or P2 Dust masks
- Protective Glasses / Goggles
- Ear Plugs / Ear Muffs – Class 5
- Gloves, long sleeve shirt and long pants
- Protective footwear

Hazardous Materials

For MSDS of all components sold by Nasahi®, please visit our website.

SYSTEM MAINTENANCE

Annual inspection of control joints, penetration seals and the coating system should be carried out to ensure the prolonged longevity and weather tightness of the system.

Any damage to the coating system must be promptly repaired to ensure the integrity of the system, and substrate components are maintained.



NCC Volume One – Covers commercial, residential and public buildings defined as Class 2 to 9. Typical examples include multi-family dwellings, commercial, health buildings and anything not covered under Volume Two.

NCC Volume Two – Covers domestic constructions defined as Class 1 and 10. Typical examples include single-family dwellings, houses and garages.

It is the responsibility of the builder to ensure the system is designed in accordance with this installation manual and that all site-specific performance provisions outlined in the relevant sections of the NCC are met.

The Nasahi® External Wall System has been certified to meet the following provisions of the National Construction Code for Volume One and Volume Two as listed below:

	Volume One	Volume Two
Structural	BP1.1 & BP1.2	P2.1.1
Fire	CP1, CP2, CP3 & CP4	P2.3.1
Bushfire	GP5.1	P2.3.4
Weatherproofing	FP1.4	P2.2.2 & 2.2.3
Acoustic	FP5.2 & FP5.5	P2.4.6
Energy Efficiency	JP1	P2.6.1

The Nasahi® CodeMark Certificate can be downloaded from our website.





MATERIAL PROPERTIES

Property	Standard	Value	Units
Ambient Density, amb	AS/NZS 4456.8	650	kg/m ³
Dry ¹ Density, dry	AS 5146.2	495	kg/m ³
Mean Compressive Strength	AS 5146.2	4.3	MPa
Characteristic Unconfined Compressive Strength, f'uc	AS 5146.2	2.8	MPa
Mean Flexural Strength	AS 5146.2	1.07	MPa
Characteristic Flexural Strength, f'ut	AS 5146.2	0.50	MPa
Mean Cold Water Absorption	AS/NZS 4456.14	69.0	%
Design Serviceability Limit State Deflection Limit, max	AS 1170	SPAN/240	

Notes: 1. Dry density is achieved by oven drying specimens so that the moisture content is close to 0%.

PANEL REINFORCING LAYOUT

50MM THICK PANEL (50 X 600 X 2200)

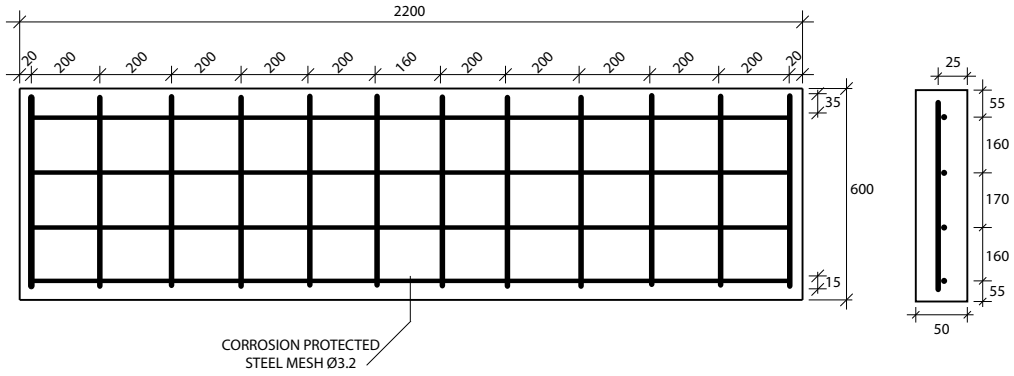

62MM THICK PANEL (62 X 600 X 2200)

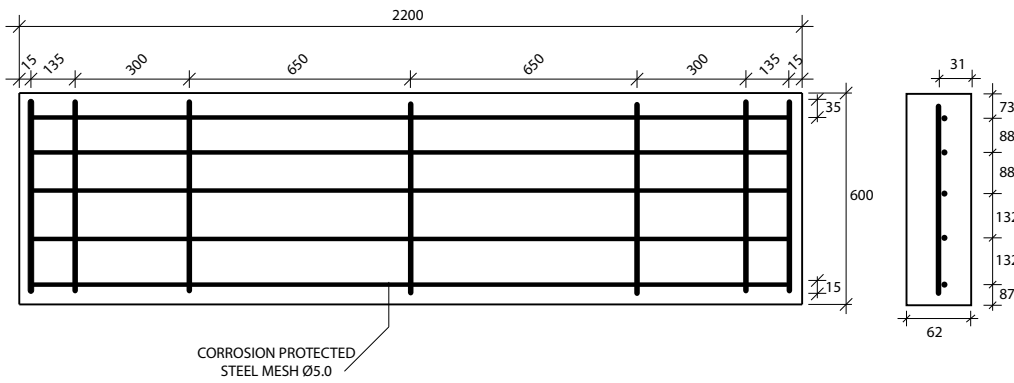

75MM THICK PANEL (75 X 600 X 2200)

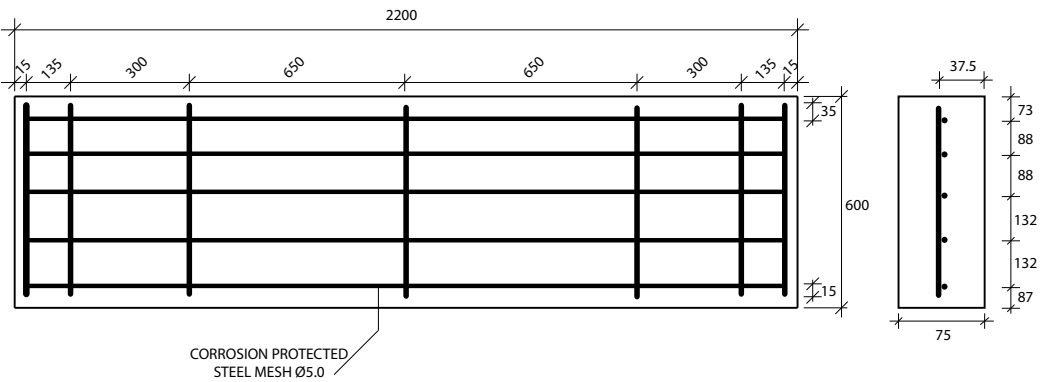

BATTEN AND FIXING REQUIREMENTS

600MM STUD CENTRES

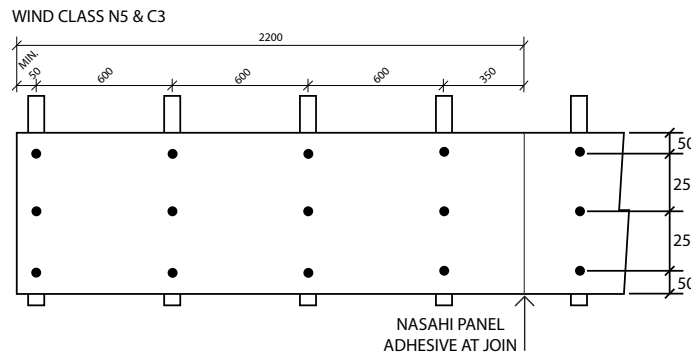
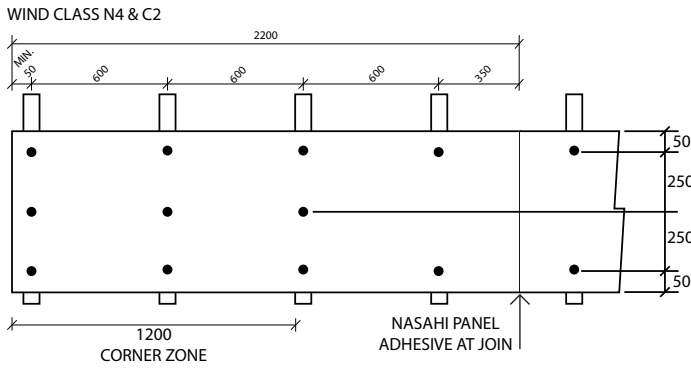
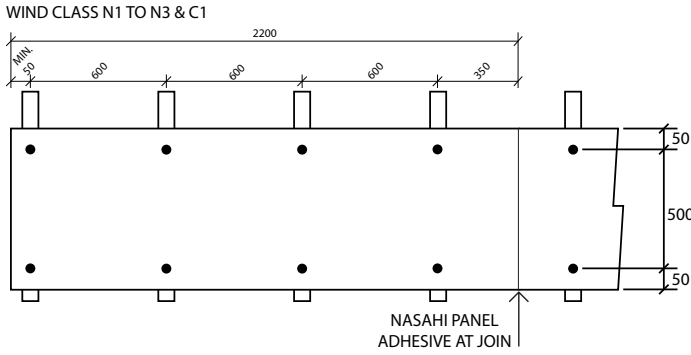

450MM STUD CENTRES

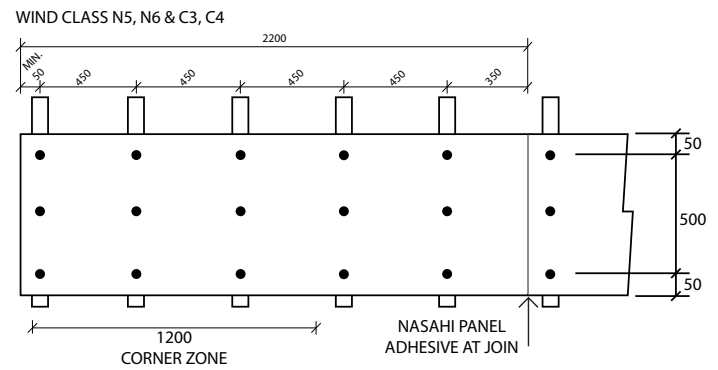
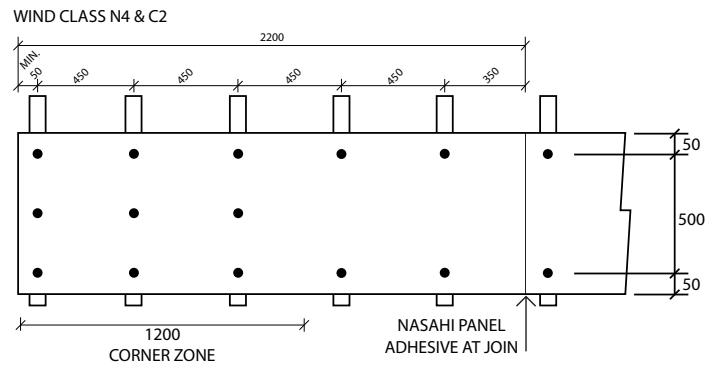
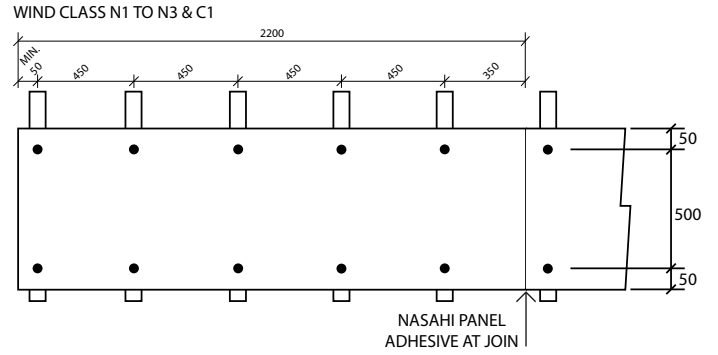

PANELS ARE NOT TO BE USED ON 600MM STUD FRAMES IN WIND CLASS N6 & C4

DETAILED DRAWINGS

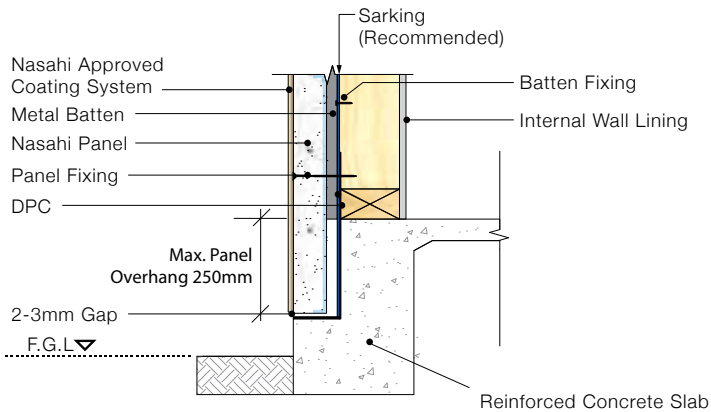

DETAIL 1.1 - Slab Edge Detail (Rebate)

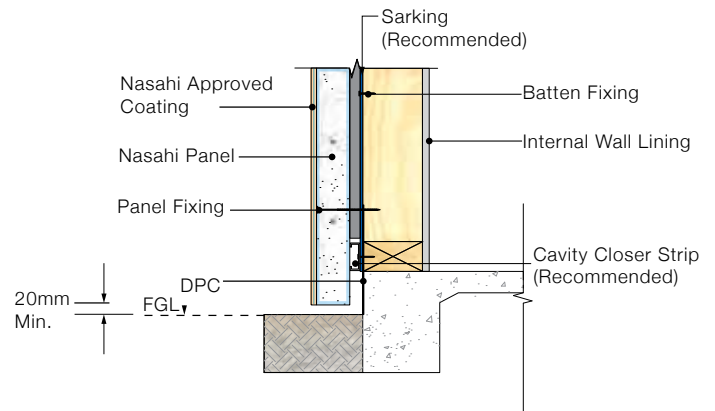

DETAIL 1.2 - Slab Edge Detail (Overhanging)

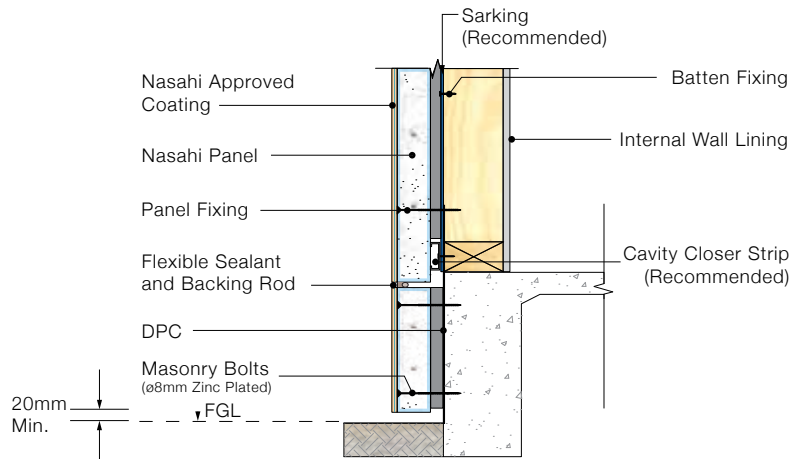

DETAIL 1.3 - Slab Edge Detail (Overhanging Deepened Edge Beam)

NOTE:
Sunfloor panels to be fixed to infill frame in between concrete stumps as per design installation guide (Detail drawings).

All framing in the subfloor to be treated pine.

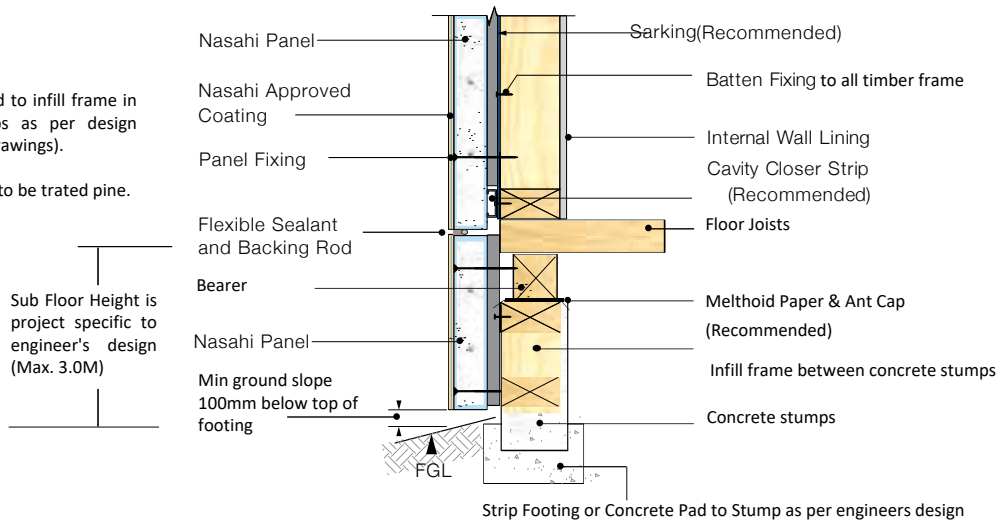

DETAIL 1.3A Sub-floor Infill Between Stumps

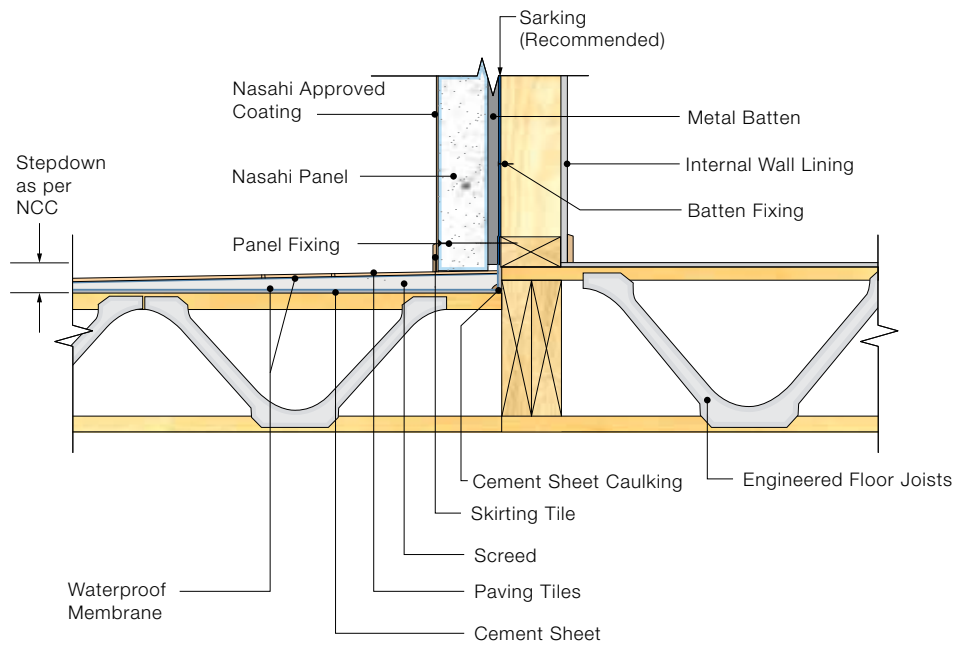

DETAIL 1.4 - Balcony Detail (Timber Frame)

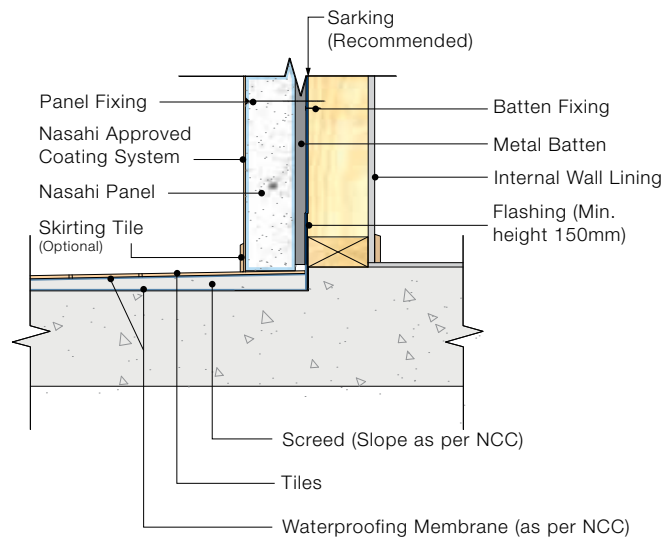

DETAIL 1.5 - Balcony Detail (Concrete Slab)

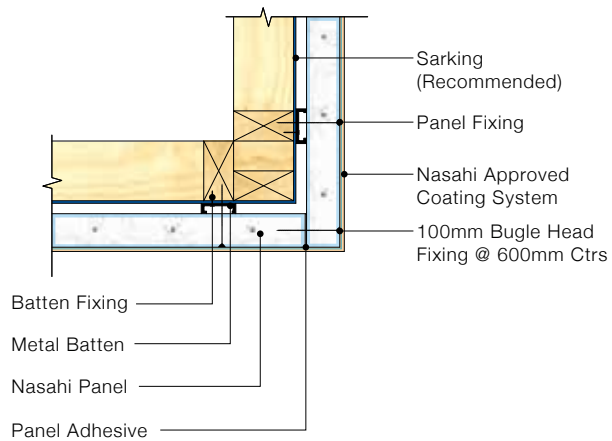

DETAIL 2.1 - External Corner Detail

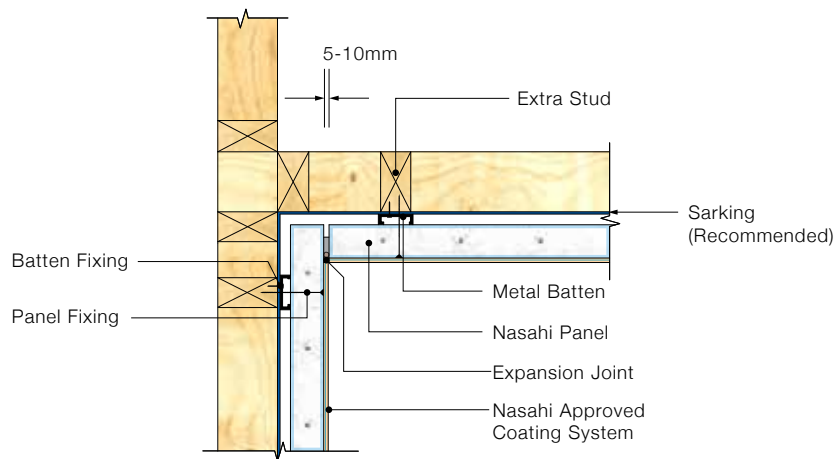

*NOTE: Internal corners require an extra stud for panel attachment 150mm back from the internal corner.

DETAIL 2.2 - Internal Corner Detail

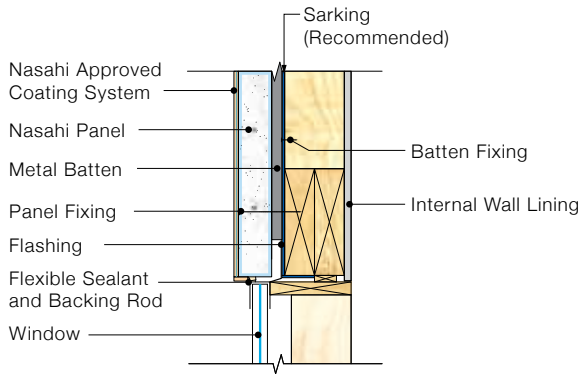

DETAIL 3.1 - Window Head

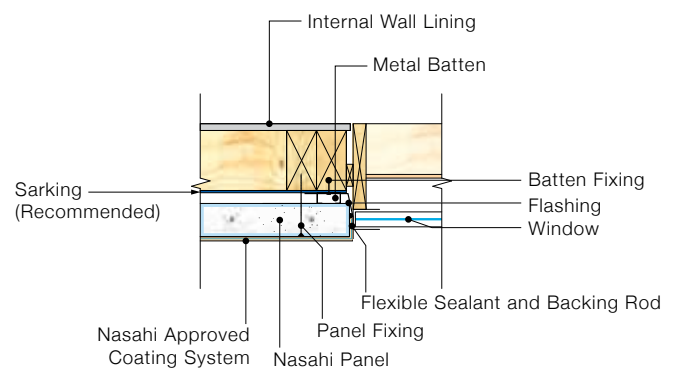

DETAIL 3.2 - Window Jamb

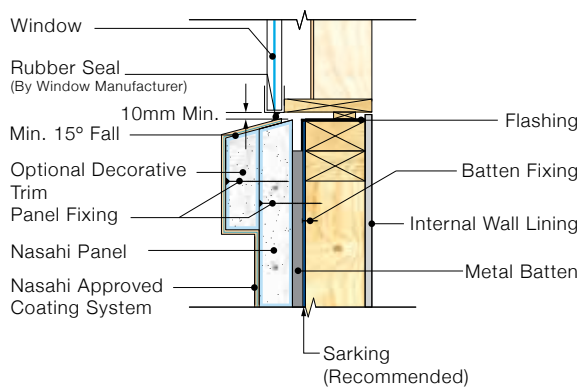

DETAIL 3.3 - Window Sill (Decorative Trim)

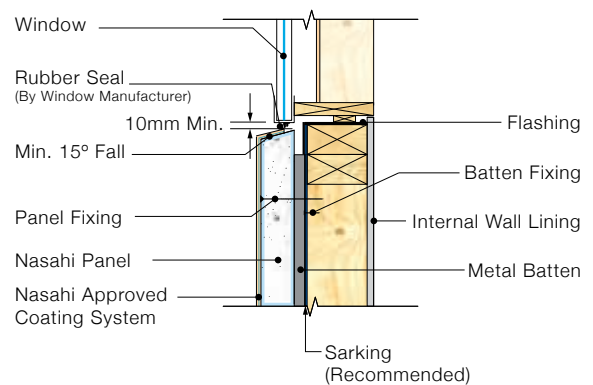

DETAIL 3.4 - Window Sill

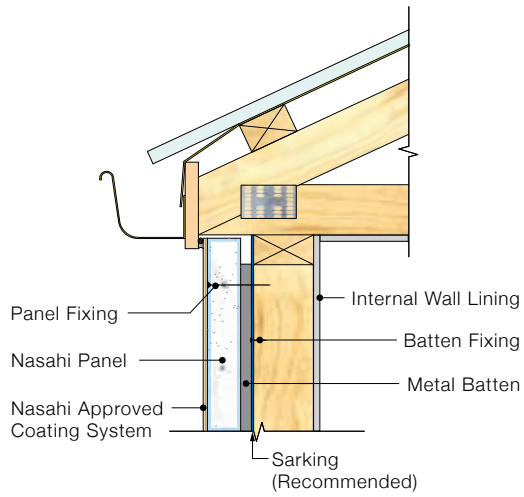

DETAIL 4.1 - Flush Eave

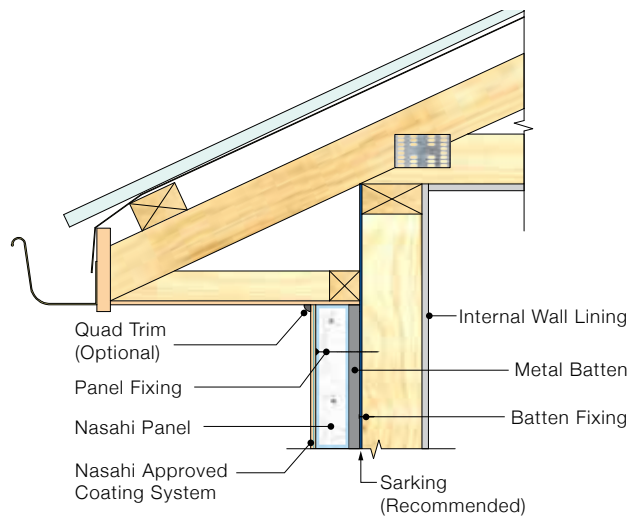

DETAIL 4.2 - Eave Detail (Panel Under)

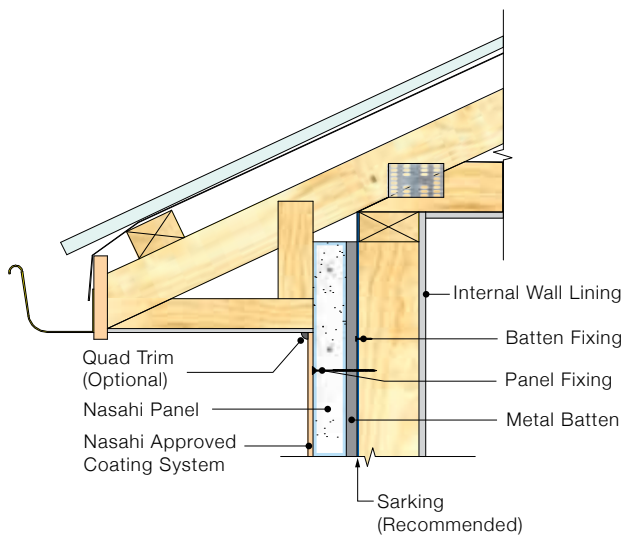

DETAIL 4.3 - Eave Detail (Panel Flush With Lining)

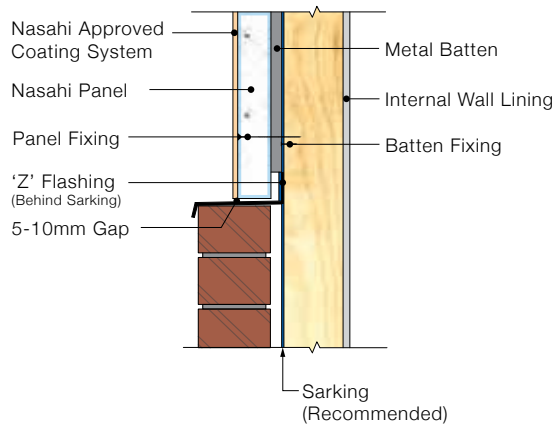

DETAIL 5.1 - Cladding to Brick Detail

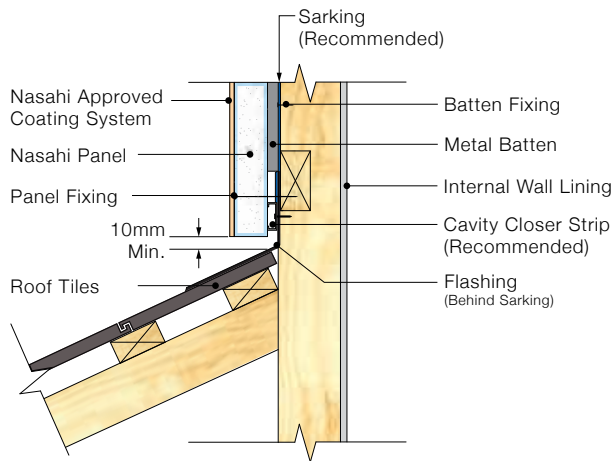

DETAIL 5.2 - Panel to Angle Roof Detail (up to 25°)

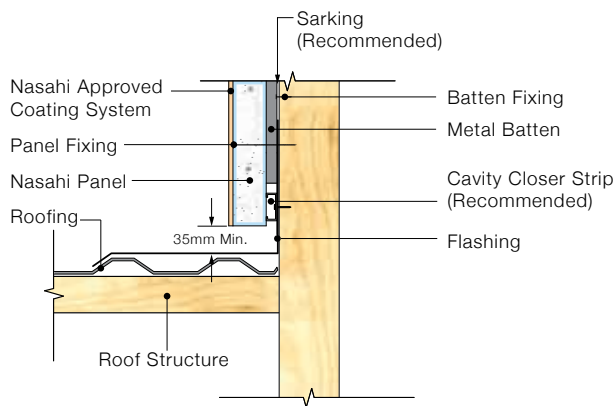

DETAIL 5.3 - Panel to Flat Roof Detail



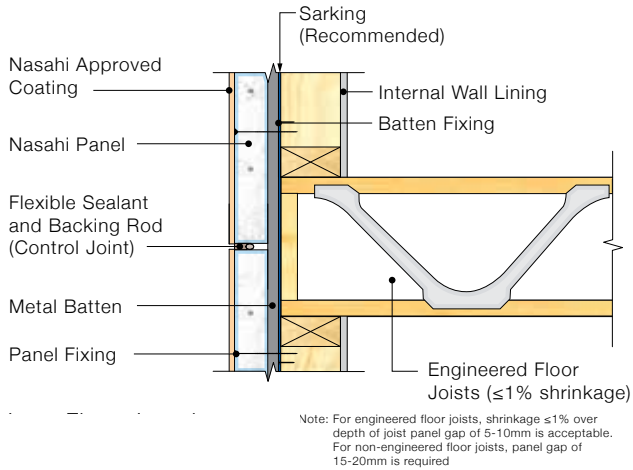

DETAIL 6.1 - Inter Floor Junction (Panel Joint in Joist Zone)

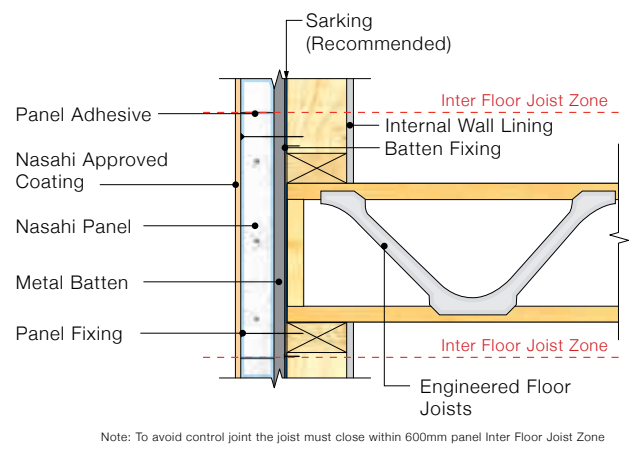

DETAIL 6.2 - Inter Floor Junction (No Panel Joint in Joist Zone)

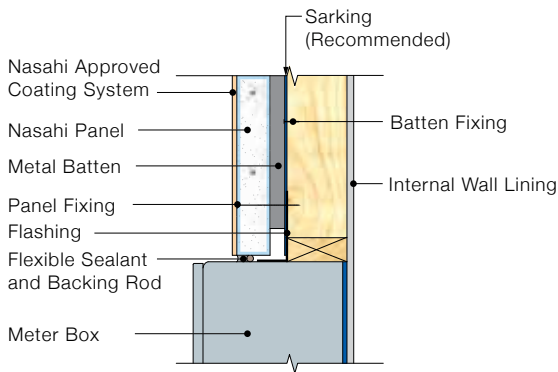

DETAIL 7.1 - Meter Box Installation

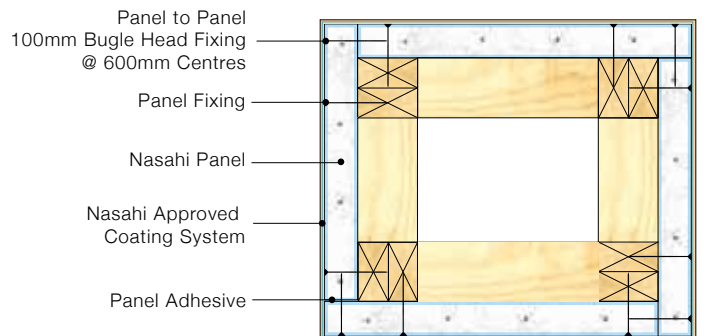

DETAIL 8.1 - Column Detail

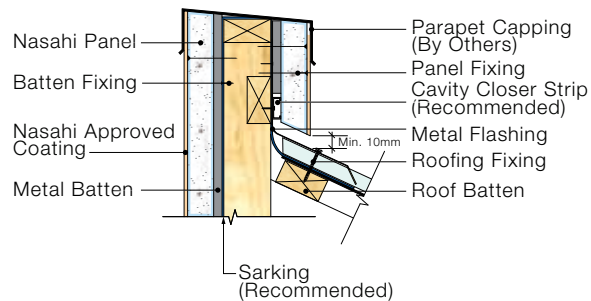

DETAIL 9.1 - Parapet Detail

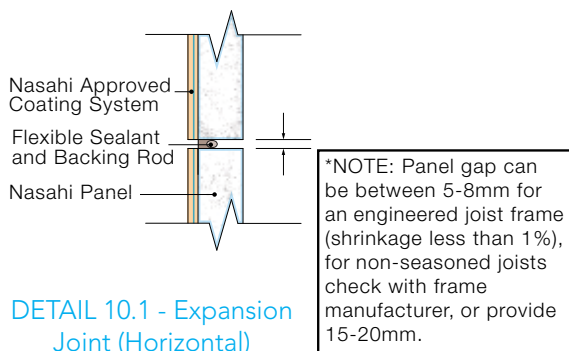

DETAIL 10.1 - Expansion Joint (Horizontal)

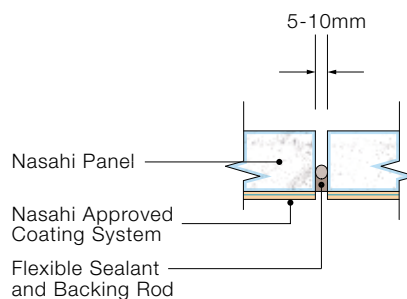

DETAIL 10.2 - Expansion Joint (Vertical)

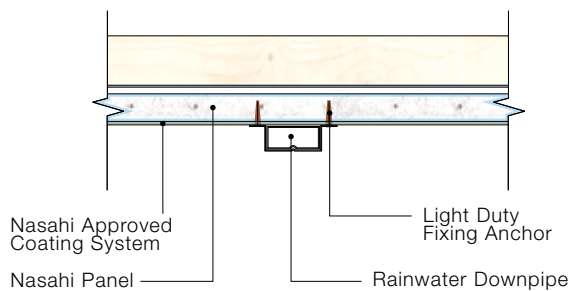

DETAIL 11.1 - External Fixings to Wall

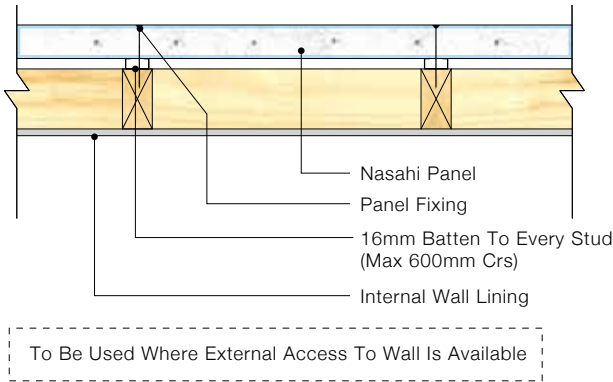

DETAIL 12.1 - Standard External Wall Detail

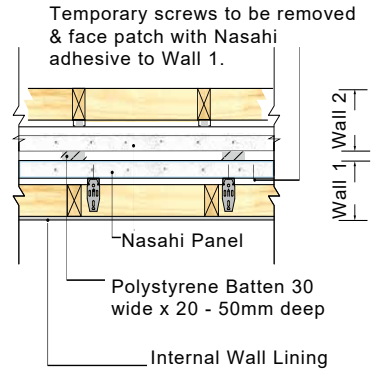

Face Patching Temporary Screw Holes

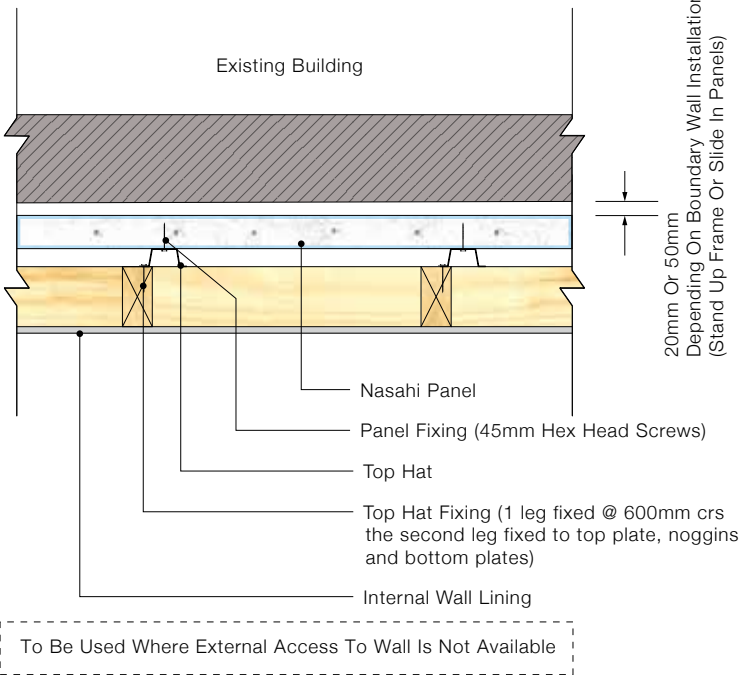

DETAIL 12.2 - Boundary Wall Fixing Detail A

If temporary screws penetrate both panels (Wall 1 & Wall 2) both need to be face patched with Nasahi adhesive to Wall 1.

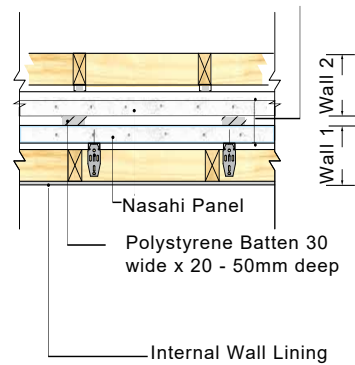

Face Patching Temporary Screw Holes

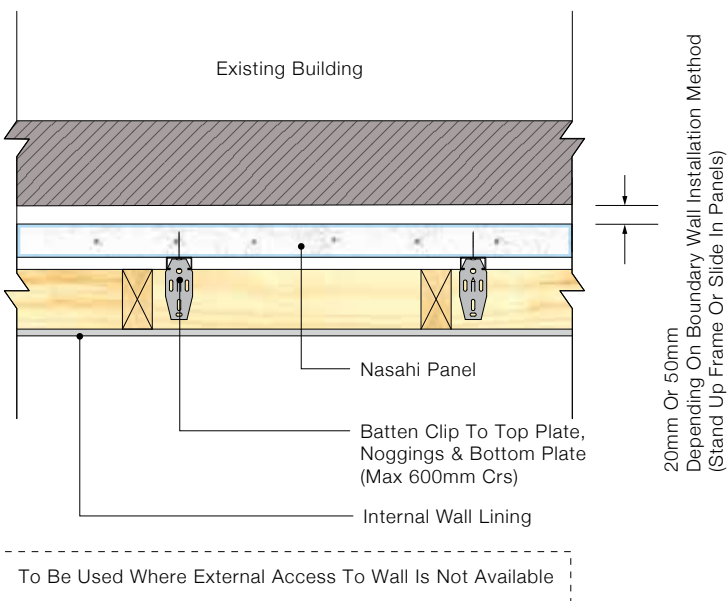

DETAIL 12.3 - Boundary Wall Fixing Detail B

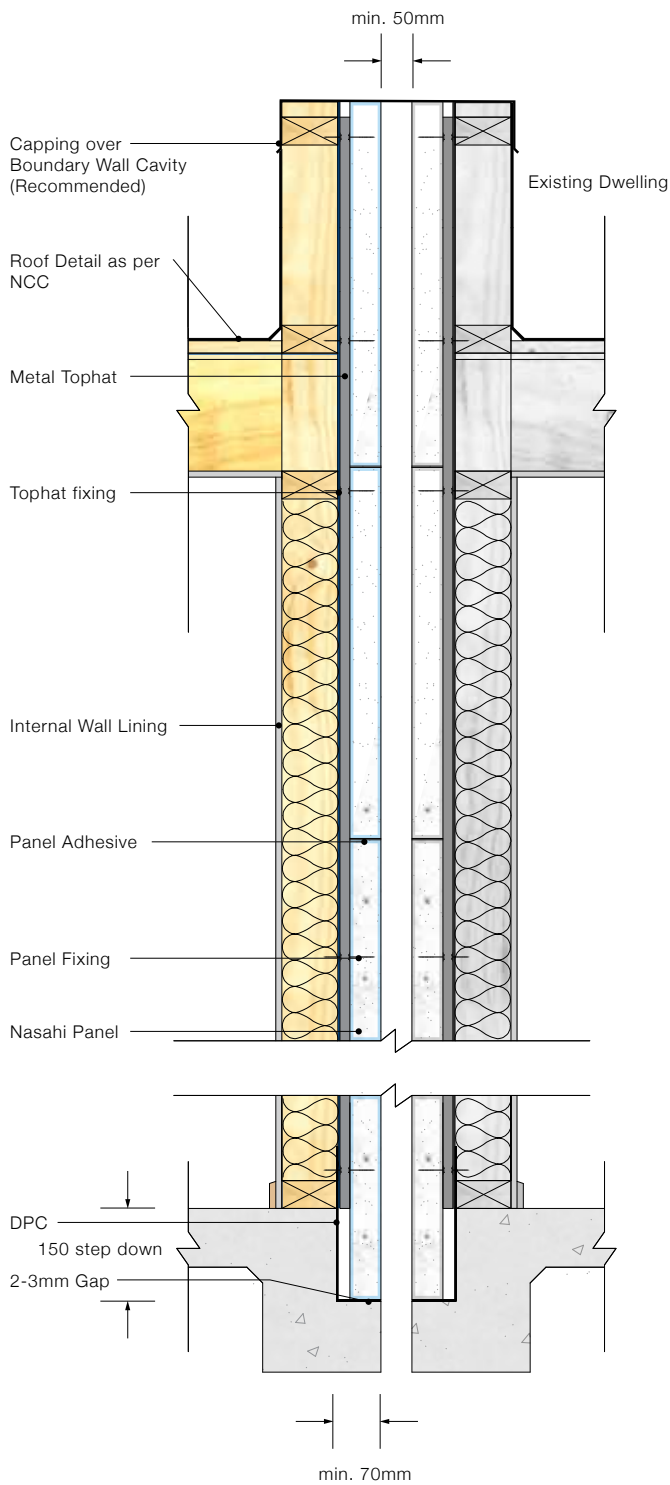

DETAIL 13.1 - Boundary Wall Detail (Even Slab)

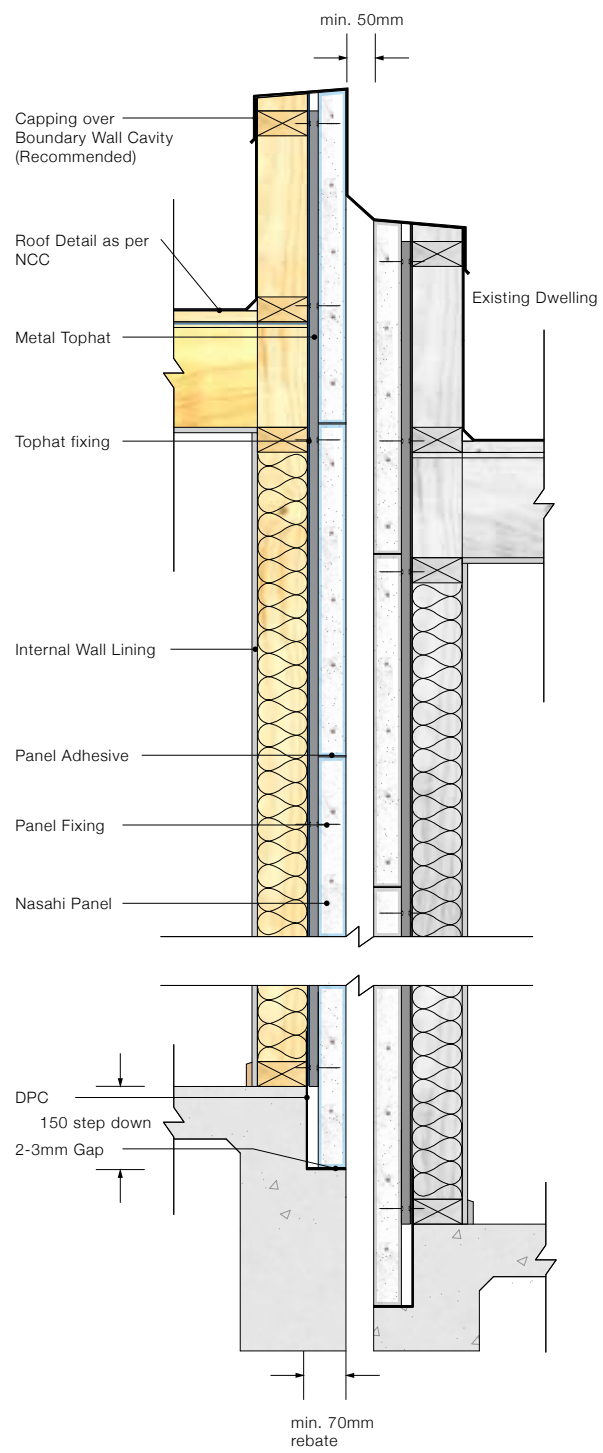

DETAIL 13.2 - Boundary Wall Detail (Uneven Slab)

Note:
Panels may be directly fixed to frame of Existing Dwelling.

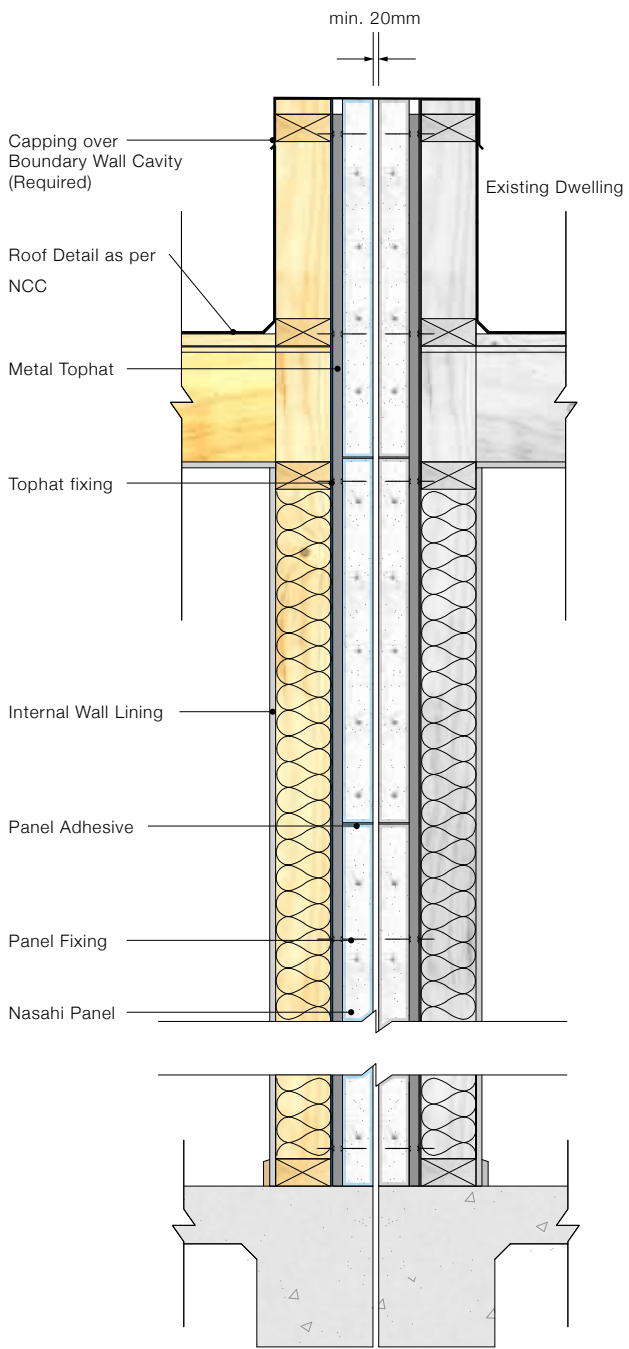

DETAIL 13.3 - Boundary Wall Detail
(Even Slab, Without Slab Rebate)

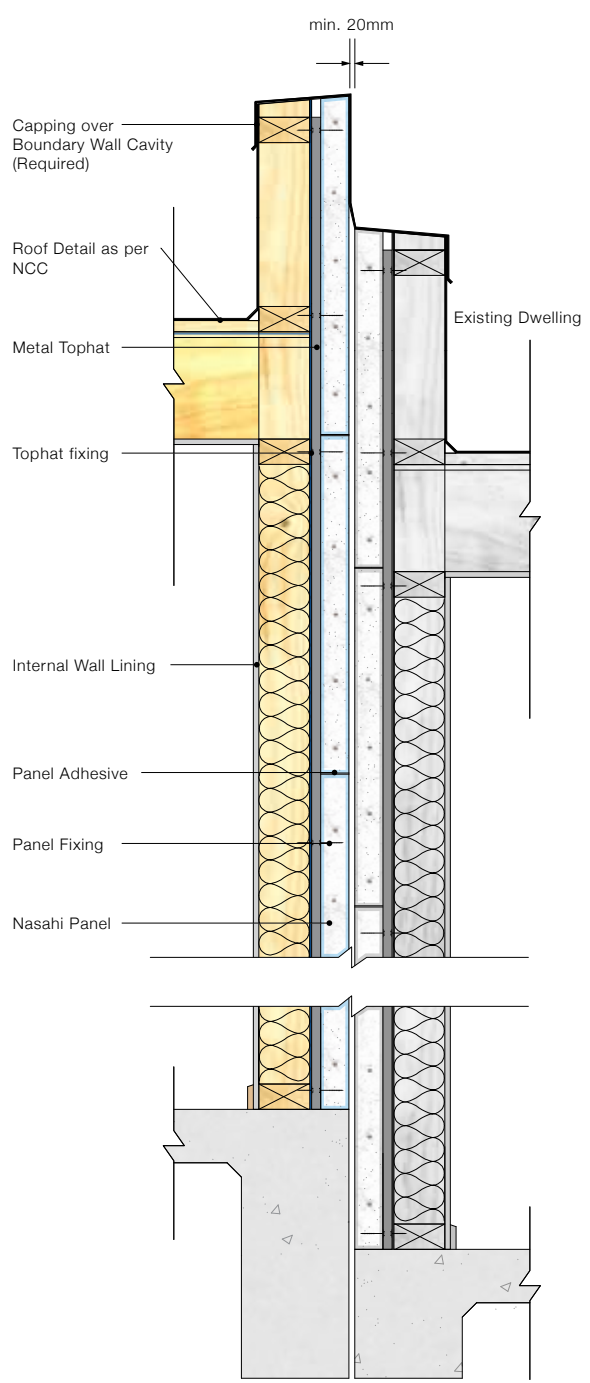

DETAIL 13.4 - Boundary Wall Detail
(Uneven Slab, Without Slab Rebate)

Note:
Panels may be directly fixed to frame of Existing Dwelling.

Guarantee

Nasahi® guarantee the products manufactured by us and the systems described in Nasahi® literature for 7 years, subject to the terms and conditions of the Nasahi Guarantee which can be found on our website. Nasahi does not guarantee components, products or services, such as installation, supplied by others. Nasahi recommends that only products, components and systems recommended by it be used.

Nasahi® Approved Coating Systems used with the Nasahi® External Wall System must be guaranteed by the coating manufacturer, and meet the minimum performance requirements specified by Nasahi®. It must have been prepared and installed in accordance with the manufacturers written instructions and technical specifications.

Only projects for which a completed Nasahi® Installation Compliance Certificate has been received will be eligible for the Nasahi® guarantee. Blank certificates are available from our website.

This guarantee applies to the performance of the system for the uses outlined in this Installation Guide and excludes liability for consequential damage or losses in connection with defective cladding, other than those imposed by legislation.

Warranty

The Nasahi® Systems, when installed in accordance with this guide, are warranted for a minimum of 15 years (from date of purchase) to be free from any defects subject to the conditions and exclusions set out in the Nasahi® Warranty Document available at our website.

Nasahi® Products are warranted to not materially degrade, corrode or break down during the Term of this warranty (Nasahi® Warranty Document).

This exceeds the 7-year requirement outlined in the NCC and the relevant Australian Standards.

Disclaimer

The information presented within this Installation Guide is provided in good faith and to the best of our knowledge is accurate at the time of preparation. The provision of this information should not be interpreted as a recommendation to use any of our products in violation of patent rights or in breach of statutes or regulations. Users are advised to make their own determination as to the suitability of this information in relation to their particular project and circumstances. As the information contained within this Installation Guide may be applied under conditions beyond our control, no responsibility can be accepted by Nasahi®, or its staff for any losses or damage caused by any person acting or refraining from action as a result of misuse of this information.

